

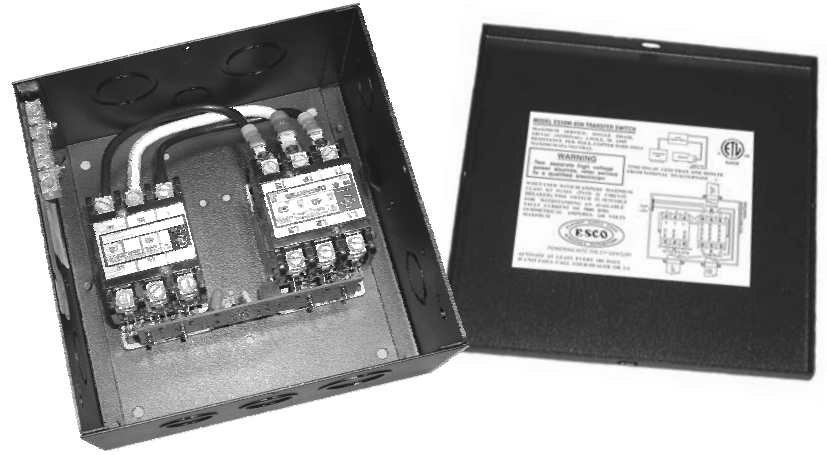

MODEL # ES50M-65N
240VAC 50 AMPS/POLE
65 AMP NEUTRAL



AUTOMATIC TRANSFER SWITCH

- AUTOMATICALLY SWITCHES FROM POWER CORD TO GENERATOR
- HEAVY DUTY CONTACTOR ASSEMBLY SPECIFICALLY DESIGNED FOR RIGOROUS USE, WILL HANDLE 50 AMP POWER CORD AND UP TO 12KW GENERATOR
- TRANSFERS BOTH HOT AND NEUTRAL LEGS SIMULTANEOUSLY
- ECONOMICAL AND RELIABLE TIME DELAY SWITCHES AUTOMATICALLY FROM SHORELINE TO GENERATOR POWER
- CAPABLE OF MONITORING FOR LOW GENERATOR VOLTAGE
- BUILT-IN TIME DELAY ALLOWS GENERATOR TO GET UP TO SPEED
- QUICK AND EASY INSTALLATION
- DESIGNED FOR OEM AND AFTERMARKET APPLICATIONS



GeneratorJoe

4016 Quartz Drive
Santa Rosa, CA 95405
Phone: 707 539-9003
Fax: 707 539-5212
Email: sales@generatorjoe.NET
Web www.generatorjoe.NET

The ES50M-65N is intended for use as an electrical transfer switch to automatically switch multiple sources (from one to another), i.e. switching from shoreline to generator power.

The ES50M-65N is primarily designed for installation in conjunction with a generator having a rated output no larger than 12KW and an external power cord having a rated output no larger than 2 pole, 240VAC, 50A, 1PH, 60HZ .

ES50M-65N INSTALLATION DIAGRAM

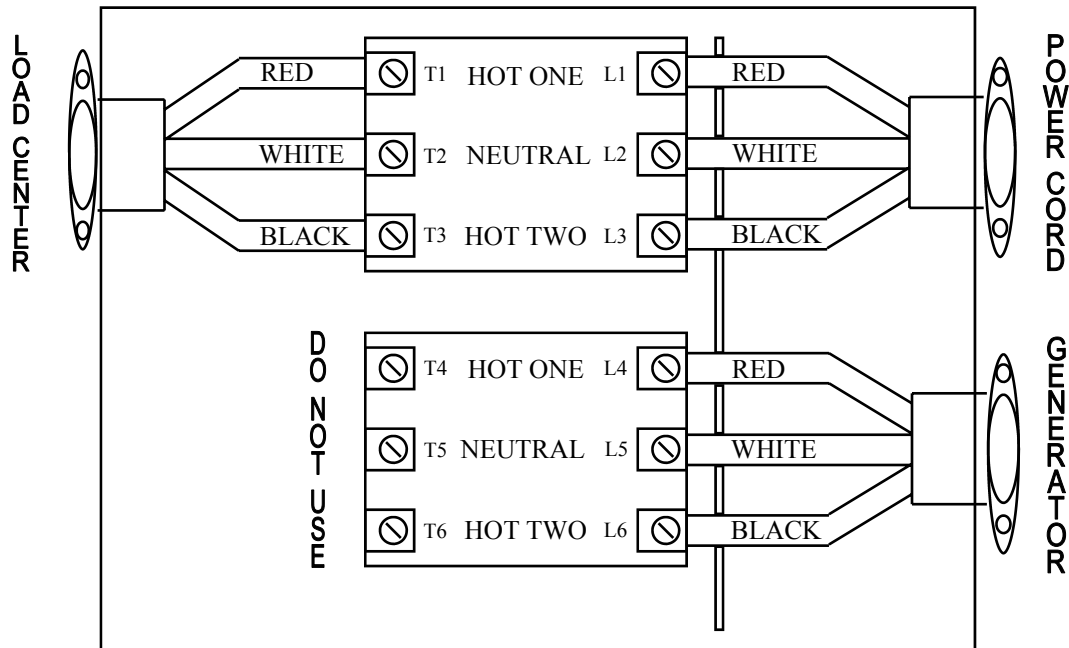

CONTACTORS: 3 Pole N.O. 240 VAC 50Amps/Pole

PHYSICAL SIZE: 8 1/2" x 8 1/2" x 4 1/2"

COIL: 110VAC (60Hz, Inrush current - 77 Watts, Sealed - 4.0 Watts)

KNOCKOUTS: Assorted

TIME DELAY: Custom time delay, 30 seconds nominal. Includes generator low voltage monitoring

WEIGHT: 8.5 lbs

CAUTIONS: ** INSTALL VERTICALLY OR HORIZONTALLY IN A DRY, ACCESSIBLE AREA.
** CONSULT FACTORY BEFORE DRILLING METAL CASE.
** KEEP COVERED EXCEPT DURING WIRING AS CONTACTORS ARE SENSITIVE TO DUST AND DEBRIS.
** WHEN HI-POTTING COACH, DISCONNECT ES50M-65N OR HI-POT ON LOAD SIDE OF SWITCH. THIS UNIT HAS BEEN HI-POTTED TO UL STANDARDS AT THE FACTORY.

WARRANTY: The manufacturer warrants that this product shall be free from defects in material and workmanship for one year (twelve months) from date of purchase or eighteen months after date of manufacture, whichever is less. If, after our inspection, a defect is revealed, the unit will be repaired and returned, at our discretion. We will accept up to 1/2 hour (30 minutes) labor for the unit to be changed out or \$18.00, whichever is less. This warranty shall not apply to any product that shows evidence of neglect, misuse, improper installation, or that has been repaired or altered by any other party other than this company. Proof of purchase may be required.

GeneratorJoe