

Operator's Manual

ASCO® 7000 Series ACTB Automatic Closed-Transition Transfer & Bypass-Isolation Switches 600 and 800 amp. sizes

TABLE OF CONTENTS

	section-page
INSTALLATION	1-1
Mounting	1-1
Power Connections	1-1
Engine Starting & Auxiliary Circuits	1-1
Functional Test	1-2, 1-3
TESTING & SERVICE	2-1
Transfer Test	2-1
Preventive Maintenance	2-1
Disconnecting the Control Panel	2-1
Manual Load Transfer	2-2
Trouble-Shooting	2-2
BYPASSING & ISOLATING	3-1
Bypassing the ATS	3-1
Isolating the ATS	3-2
Return to Service	3-3
INDEX	back cover

Note: Refer to the outline and wiring drawings provided with your 7000 Series ACTB for all installation and connection details and accessories.

Note: Refer to *Group 5 Control Panel User's Guide* 381333-126 for ATS status display messages, time delays, pickup & dropout settings, and adjustments.

Rating Label

Each 7000 Series ACTB contains a rating label to define the loads and fault circuit withstand/closing ratings. Refer to the label on the Transfer Switch for specific values.

WARNING

Do not exceed the values on the rating label. Exceeding the rating can cause personal injury or serious equipment damage.

Nameplate

The Transfer Switch nameplate includes data for each specific 7000 Series 7ACTB. Use the switch only within the limits shown on this nameplate. A typical Catalog Number is shown below with its elements explained:

An experienced licensed electrician must install the ACTB.

Catalog Number Identification

Typical 7000 Series ACTB catalog no. for overlapping neutral, 3 pole, 800 amp, 480 V, in Type 1 enclosure:

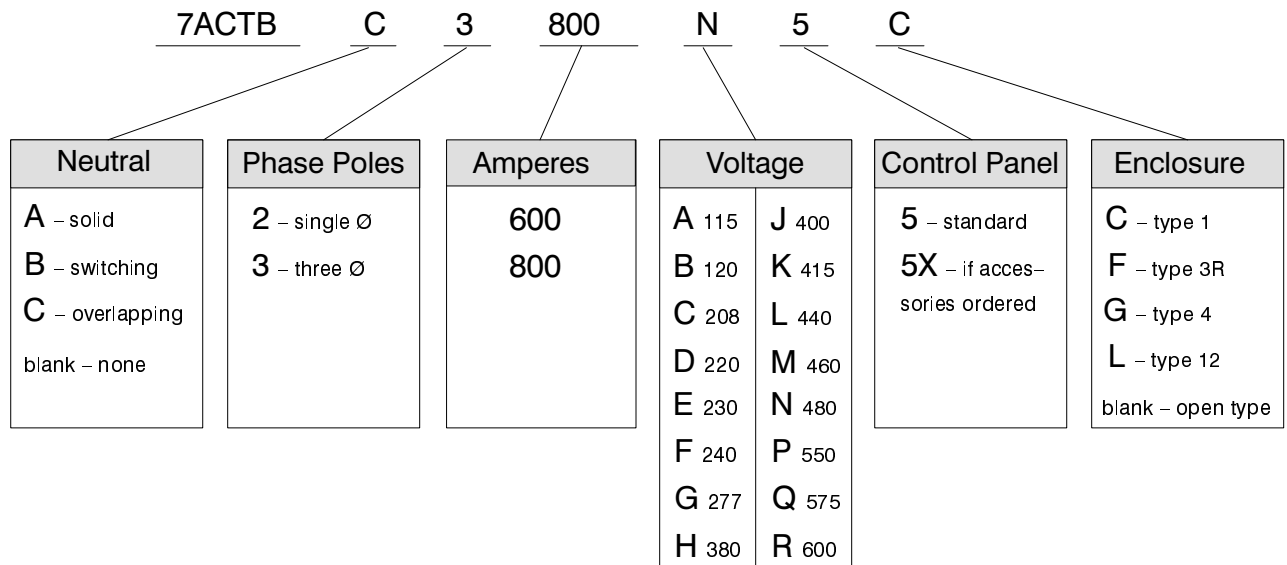

SECTION 1 INSTALLATION

The ASCO 7000 Series Automatic Closed–Transition Transfer & Bypass–Isolation Switch (ACTB) consists of an upper bypass–isolation switch, a lower transfer switch, a monitoring and transfer control panel, and door–mounted controls. The ACTB is factory wired & tested.

CAUTION

Protect the switch from construction grit and metal chips to prevent malfunction or shortened life for the ACTB switch.

CAUTION

To prevent damage to open–type switches, use care when lifting them. Fasten lifting chains or hooks to the main structural parts of the switch, such as the main panel or mounting rails. Do not damage moving linkages, shafts, contacts, wires, and control contacts.

Mounting

Refer to the enclosure outline drawing furnished with this switch and mount the 7000 Series ACTB according to the details and instructions shown on the drawing.

It is not necessary to remove the barriers from the bypass switch and transfer switch. If you do remove them, however, reinstall them carefully.

Enclosed switches have the control panel mounted on the upper door. For open–type switches, mount the control panel in the door with appropriate size cutout and mounting studs (as shown on the drawings). Do not exceed the length of the harness; provide stress relief.

Harnesses

All internal connections are made at the factory. The bypass switch, transfer switch, and control panel are joined together by an interconnecting wire harness. The disconnect plugs are already engaged on enclosed switches. For open–type switches, the plugs must be engaged after installation is completed. Align harness plugs with sockets in the control and push them together until they are secure.

Power Connections

A *Wiring Diagram* is furnished with the ACTB. All wiring must be made in accordance with the the National Electrical Code and local codes.

DANGER

De–energize the conductors before making any line or auxiliary circuitry connections. Be sure that Normal and Emergency line connections are in proper phase rotation. Place engine generator starting control in the OFF position. Make sure engine generator is not in operation.

Do not run cables behind the switch. Cables can be bundled on the upper left side of the switch. Maintain proper electrical clearance between the live metal parts and grounded metal: 1 inch minimum.

Connect the power cables to the appropriate terminal lugs on the Bypass Switch as shown on the wiring diagram provided with this ACTB. Make sure that the lugs provided are suitable for use with the cables being installed. Standard terminal lugs are solderless screw type and will accept the wire sizes listed on the drawings provided with the ACTB. Be careful when stripping insulation from conductors; avoid nicking or ringing the conductor. Remove surface oxides from conductors by cleaning with a wire brush. Follow conductor manufacturer's instructions when aluminum conductor is used. Apply joint compound to conductor, then carefully wipe away excess compound. Tighten the cable lugs to the torque specified on the rating label.

CAUTION

Be sure that the Normal and Emergency power connections are in proper phase rotation.

Engine Starting Contacts and Auxiliary Circuits

The engine control contact signal connections and auxiliary circuits are located on a terminal block as shown on the *Wiring Diagram* provided with the ACTB. Connect the signal wires to the appropriate terminals.

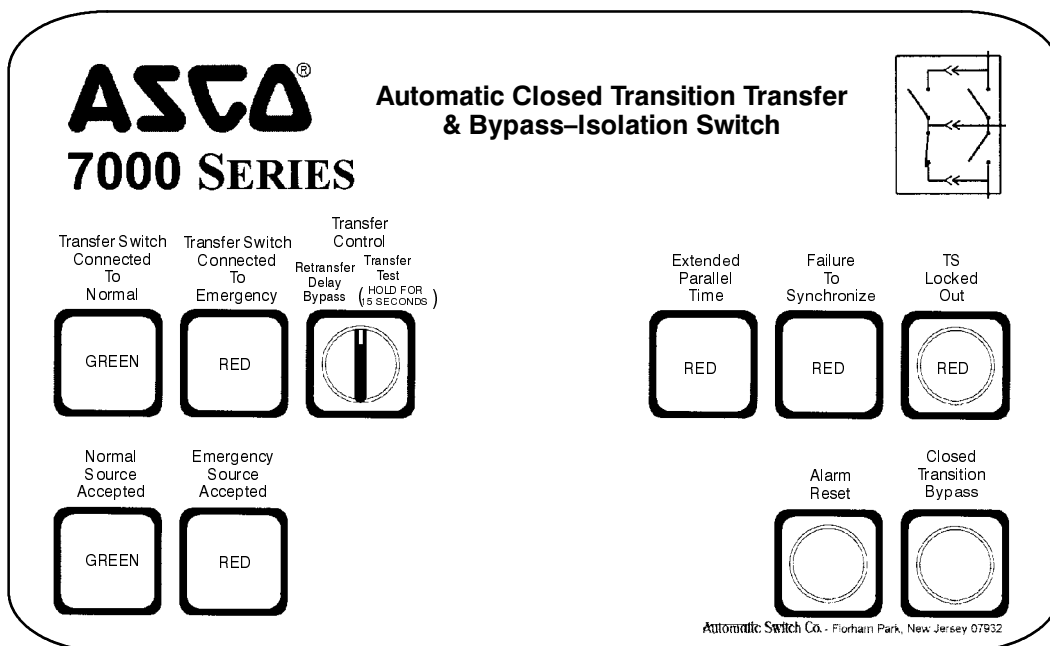

Figure 1-1. Standard controls and indicators.

Functional Test

Read all instructions on the *Wiring Diagrams* and labels affixed to the ACTB. Note the control features that are provided and review their operation before proceeding.

After installing the ACTB check the following:

- Bypass Handle should be in the *OPEN* position.
- Isolation Handle should be in the *CLOSED* position.
- CN transfer switch should be *CLOSED*.
- CE transfer switch should be *OPEN*.

If handles are not in correct positions, follow instructions for Bypassing and Isolating the automatic transfer switch in **Section 3**. **Do not force the handles.** Electrical interlocks prevent a wrong sequence of operation.

1 – Voltage Checks

First check nameplate on transfer switch; rated voltage must be the same as normal and emergency line voltages.

DANGER

Use extreme caution when using a meter to measure voltages. Do not touch power terminals; shock, burns, or death could result !

Perform steps 1 through 6 at the right. Observe the status lights. See Figure 1-1.

- Black square means light is on.
- White square means light is off.

* If necessary, adjust voltage regulator on generator per the manufacturer's recommendations. The ACTB will respond only to rated voltage specified on the nameplate.

Now continue to **2 – Electrical Operation** on next page.

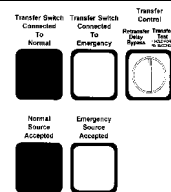
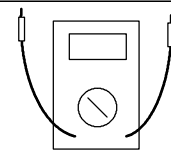
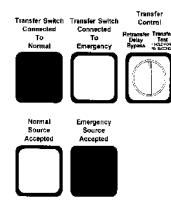
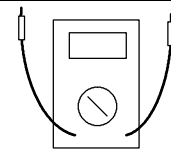
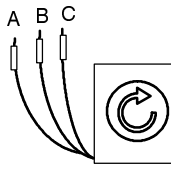
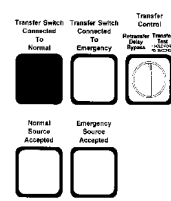
1	Close the normal source circuit breaker. The <i>Transfer Switch Connected To Normal</i> and the <i>Normal Source Accepted</i> lights should come on.	
2	Use an accurate voltmeter to check phase to phase and phase to neutral voltages present at the transfer switch normal source terminals.	
3	Close the emergency source circuit breaker. Turn the Engine Control switch to <i>Run</i> to start the generator. The <i>Transfer Switch Connected To Normal</i> & <i>Emergency Source Accepted</i> lights should come on.	
4	Use an accurate voltmeter to check phase to phase and phase to neutral voltages present at the transfer switch emergency source terminals.*	
5	Use a phase rotation meter to check phase rotation of emergency source; it must be the <u>same</u> as the normal source.	
6	Turn Engine Control switch to <i>Auto</i> to stop the generator. The <i>Emergency Source Accepted</i> light should go off. Then put the starting control selector switch (on generator set) in <i>automatic</i> position. Close enclosure door.	

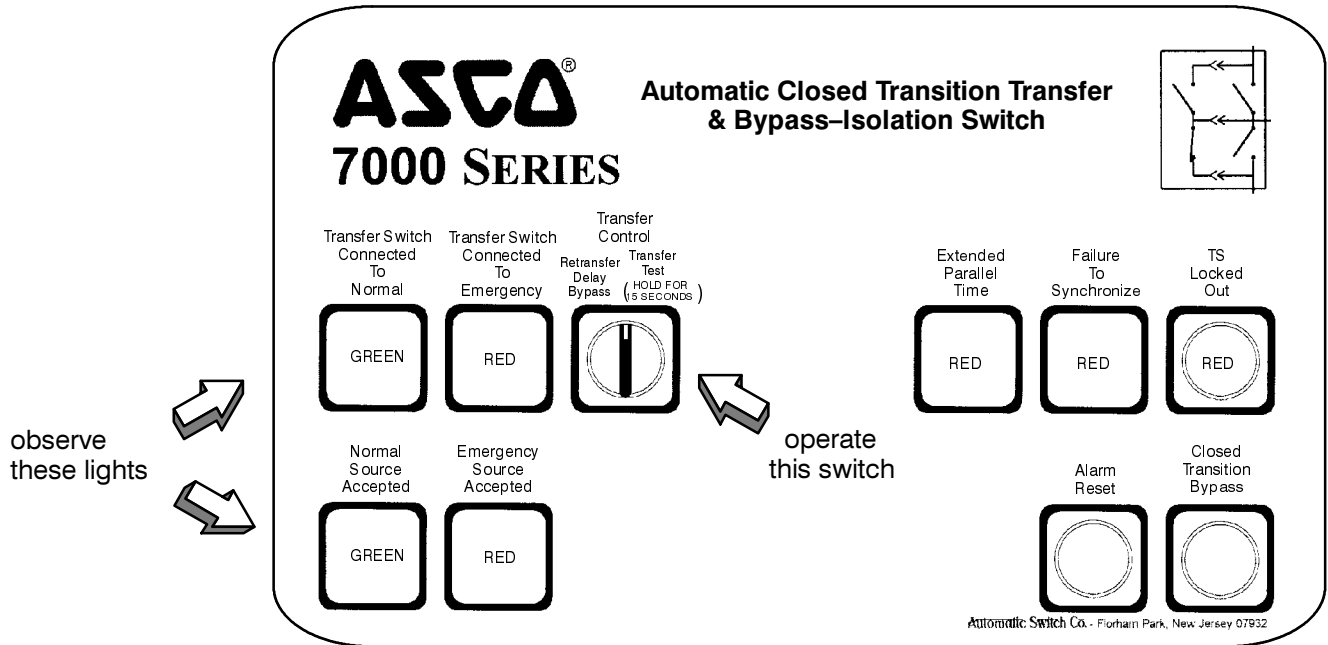

Figure 1-2. Standard controls and indicators.

2 – Electrical Operation

This procedure checks electrical operation of the ATS.

WARNING

Be sure to close the enclosure door before proceeding to prevent personal injury in case of electrical system fault.

Transfer Test

The ATS must be bypassed and isolated (test). Both normal and emergency sources must be available and the emergency source generator (if used) must be capable of being started; put engine starting control in *automatic* position. The *Transfer Switch Connected to Normal* light and the *Normal Source Accepted* light should be on.

1. Turn **Bypass Handle** clockwise to *NORMAL* position.
2. Push in the **Isolation Handle** and turn it clockwise to *T* (test).

NOTE: The engine generator may be signalled to start while turning the Isolation Handle. If emergency source is available, the ATS may operate to the emergency position. If it does, operate **Retransfer Delay Bypass** switch.

3. Perform steps 1 – 4 at right. Observe the status lights.
 - Black square means light is on.
 - White square means light is off.
4. Push in the **Isolation Handle** and turn it counterclockwise to the *CLOSE* position.
5. Turn **Bypass Handle** counterclockwise to *AUTO* pos.

This completes the Functional Test of the ACTB.

1	Turn and <u>hold</u> Transfer Control switch clockwise to <i>Transfer Test</i> until the engine starts and runs (within 15 sec.). The <i>Emergency Source Accepted</i> light should come on.	
2	Transfer switch CE closes and then Transfer Switch CN opens (closed-transition overlap). The <i>Transfer Switch Connected to Emergency</i> light should come on and the <i>Transfer Switch Connected to Normal</i> light should come on (you might see and hear the brief overlap transfer).	
3	Transfer switch will operate back to Normal position after Feature 3A time delay. For immediate retransfer turn Transfer Control counterclockwise to <i>Retransfer Delay Bypass</i> . The <i>Transfer Switch Connected To Normal</i> light should come on; <i>Transfer Switch Connected to Emergency</i> light should go off.	
4	The engine-generator will stop after the Feature 2E time delay (unloaded running engine cool-down). The <i>Emergency Source Accepted</i> light should go off.	

SECTION 2 TESTING & SERVICE

TRANSFER TEST

Test the Automatic Closed–Transition Transfer Switch portion of the 7000 Series ACTB at least once a month. This procedure checks the electrical operation of the Transfer Switch and Control Panel. Put the engine–generator starting control (at the engine–generator set) in automatic mode.

In the following test the generator will start, the load will be transferred to the Emergency source, then back to the Normal source. An interruption to the load will occur, unless the the Transfer Switch contacts are bypassed before the test. See pages 3–1 and 3–2 for bypassing & isolating instructions if no interruption of load is required.

WARNING

Be sure to close the enclosure door before proceeding to prevent personal injury in case of electrical system fault.

Perform the four–step **Electrical Operation – Transfer Test** procedure on page 1–4.

PREVENTIVE MAINTENANCE

Reasonable care in preventive maintenance will insure high reliability and long life for the 7000 Series ACTB. An annual preventive maintenance program is recommended.

ASCO Services, Inc. (ASI) is Automatic Switch Company's national service organization. ASI can be contacted at 973–966–2070 for information on preventive maintenance agreements.

Checklist for Yearly Inspection

DANGER

Hazardous voltage capable of causing shock, burns, or death is used in this switch. Deenergize both Normal – Emergency power sources before performing inspections!

- Clean the ATS enclosure.** Brush and vacuum away any excessive dust accumulation. Remove any moisture with a clean cloth.
- Check the transfer switch contacts.** Remove transfer switch barriers and check the condition of the contacts. Replace contacts when pitted or worn excessively. Reinstall the barriers carefully.
- Maintain transfer switch lubrication.** If switch is subjected to severe dust or abnormal operating conditions, renew factory lubrication on all movements and linkages. Relubricate solenoid operator if TS coil is replaced. Don't use oil; order *lubrication kit 75–100*.
- Check all cable connections & retighten them.**

REPLACEMENT PARTS

Replacement parts are available in kit form. When ordering parts provide the Serial No., Bill of Material No. (BOM), and Catalog No. from the transfer switch nameplate. Contact your local ASCO Sales Office or ASCO Services, Inc. (973–966–2070).

DISCONNECTING THE CONTROL PANEL

The harness disconnect plugs are furnished for repair purposes only and should not have to be unplugged. If the control panel must be isolated, follow these steps:

DANGER

Bypass–Isolation Switch is energized! Do not touch isolation contact fingers; shock, burns, or death could result!

Disconnecting the Plugs

1. Bypass and Isolate the Automatic Transfer Switch.
2. Open the upper enclosure door.
3. Separate the two quick disconnect plugs by squeezing the latches. Do not pull on the harness wires.

Reconnecting the Plugs

1. The ATS should be still bypassed and isolated.
2. The two harness plugs and sockets are keyed. Carefully align the plugs with the sockets and press straight in until the latches click.
3. Close the enclosure doors.
4. Follow *Return to Service* instructions on page 3–3.

TESTING & SERVICE *(continued)*

TROUBLE-SHOOTING

Note any optional accessories that may be furnished on the ACTB and review their operation. Refer to any separate drawings and/or instructions that may be packed with the ACTB.

Table 2-1. Trouble-Shooting Checks.

PROBLEM	CHECK IN NUMERICAL SEQUENCE		
	1 OPERATION	2 GEN-SET	3 VOLTAGE
Engine-generator set does not start when the Transfer Control switch is turned and held in <i>Transfer Test</i> position or when normal source fails.	Hold <i>Transfer Test</i> switch 15 seconds or the outage must be long enough to allow for Feature 1C time delay plus engine cranking and starting.	Starting control must be in the automatic position. Batteries must be charged and connected. Check wiring to engine starting contacts.	–
Transfer switch does not transfer the load to the emergency source after the engine-generator set starts.	Wait for Feature 2B time delay to time out.	Generator output circuit breaker must be closed. Generator frequency must be at least 95% of nominal (57 Hz for a 60 Hz system.) *	Voltmeter should read at least 90% of nominal phase to phase voltage between terminals EA and EC (or EL1 and EL2 for 2 pole switches)*
Transfer switch does not transfer the load to normal source when normal returns or when the Transfer Control switch is released.	Wait for Feature 3A time delay to time out.	–	Voltmeter should read at least 90% of nominal phase to phase voltage between terminals NB and NC, NC and NA, and NA and NB (or NL1 and NL2 for 2 pole switches).
Gen. does not stop after load retransfer to normal source.	Wait for Feature 2E time delay to time out.	Starting control must be in the automatic position.	–
<i>Failure to Synchronize</i> light comes on.	Conditions of Normal or Emergency Sources not suitable for closed transition transfer. Recheck voltage and frequency of both sources. Press Alarm Reset pushbutton.		
<i>Extended Parallel Time</i> light comes on.	CN and CE contacts are closed longer than setting in the Control Panel. Open the disconnected source circuit breaker, then call your nearest ASCO Service Center for assistance.		
<i>TS Locked Out</i> light comes on.	Transfer lockout operation has occurred; transfer switch is disabled from automatic operation. Open the disconnected source circuit breaker, then call your nearest ASI for assistance.		

* These are factory settings.

Refer to **Control Panel User's Guide**.

If the problem is isolated to circuits on the control panel or the transfer switch, call your local Automatic Switch Company sales office. Furnish the Serial No. and Catalog No. from the transfer switch nameplate.

MANUAL LOAD TRANSFER

This procedure manually transfers load to other source if the Transfer Switch or Control Panel are out of service.

⚠ WARNING

Close enclosure doors to prevent personal injury in case of electrical system fault.

1. Be sure that the Bypass Handle is *CLOSED* on either Emergency or Normal (see page 3-1).
2. Be sure that the Isolation Handle is in the *T* (test) or *OPEN* position (see page 3-2).
3. Turn the Bypass Handle to the *AUTO* position, then continue turning the Bypass Handle to the other source (see page 3-1).

⚠ DANGER

Hazardous voltage capable of causing shock, burns, or death is used in this switch. Do not touch the power or load terminals of the switch!

MAINTENANCE HANDLE

⚠ DANGER

Bypass and isolate Transfer Switch before using the maintenance handle! See pages 3-1 & 3-2.

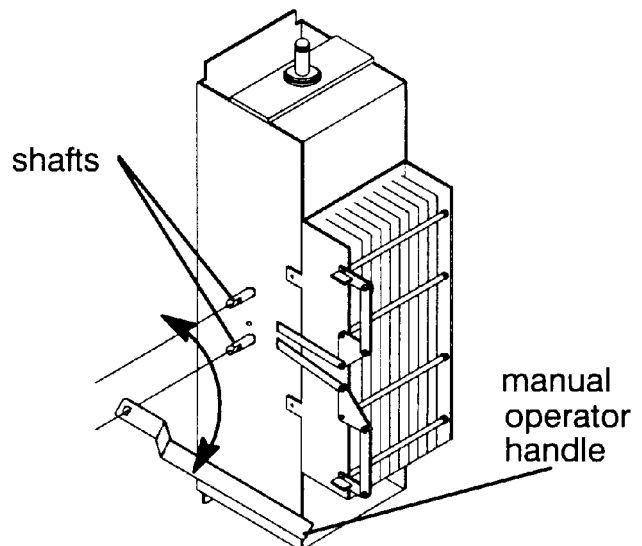

Install the handle onto end of shaft, left side. Open closed contacts, then use other shaft to close the other contacts.

SECTION 3 BYPASSING & ISOLATING

BYPASSING

This procedure explains how to Bypass the closed automatic transfer switch contacts. Bypassing is required before the ATS can be tested or isolated. The Bypass Switch must be in the *AUTO* position & the Isolation Switch contacts must be closed.

1. Observe which *Transfer Switch Connected To* light is on (*Normal* or *Emergency*) on the door. It is the position of the automatic transfer switch.
2. Bypass to the same source connected to the load as follows (select direction). Refer to Figure 3-1, Figure 3-2, and Figure 3-3.

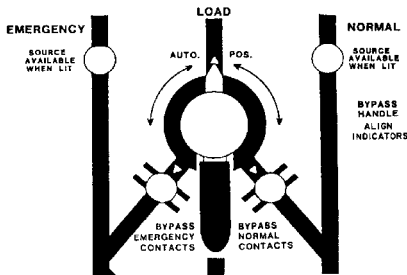

Figure 3-1. Bypass Handle.

To Bypass Normal Source

Turn the **Bypass Handle** clockwise to *NORMAL*.

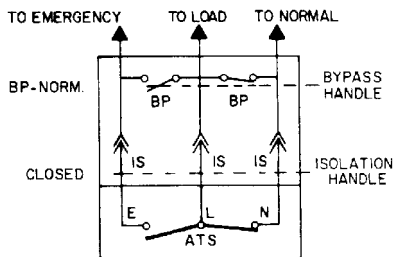

Figure 3-2. Bypass to Normal.

To Bypass Emergency Source

Turn the **Bypass Handle** counterclockwise to *EMERGENCY*.

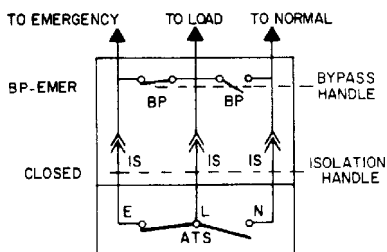

Figure 3-3. Bypass to Emergency.

The automatic transfer switch can now be put in the *TEST* or *OPEN* position. See **ISOLATING**.

ISOLATING

This procedure explains how to isolate the automatic transfer switch. Isolating is required before any service work can be performed on the ATS. Observe the *Transfer Switch Connected To* lights on the door.

1. Bypass the closed automatic transfer switch contacts. See **BYPASSING**.
2. Isolate automatic transfer switch as follows. Refer to Figure 3-4, Figure 3-5, and Figure 3-6.

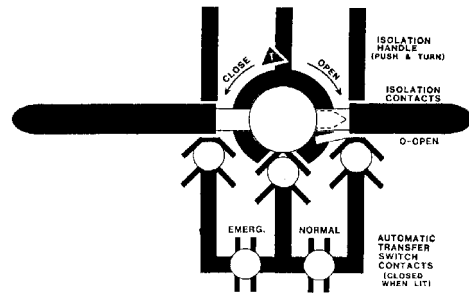

Figure 3-4. Isolation Handle.

⚠ CAUTION

Align handle indicator. Do not leave the handle in an intermediate position.

To Isolate the Automatic Transfer Switch

Push in the **Isolation Handle** and turn it clockwise to the *TEST* position. Then push in again and continue turning the Isolation Handle to the *OPEN* position. Padlock the Isolation Handle.

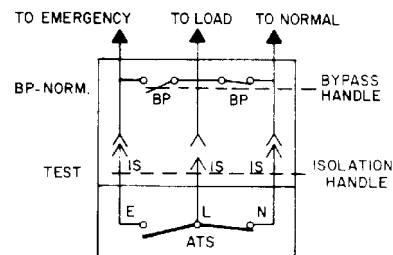

Figure 3-5. Isolate to Test.

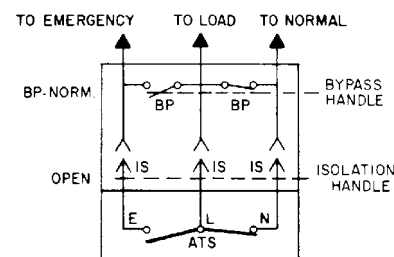

Figure 3-6. Isolate to Open.

The lower transfer switch can now be removed for inspection and maintenance. See page 3-2.

BYPASSING & ISOLATING (continued)

TRANSFER SWITCH REMOVAL

This procedure explains how to remove the transfer switch for inspection and maintenance.

1. Bypass and Isolate the automatic transfer switch by carefully following directions on page 3-1. Padlock the **Isolation Handle** in the *OPEN* position

⚠ DANGER

Hazardous voltage capable of causing electrical shock, burns, or death is used in this ACTB. Do not touch any control circuit terminals.

2. Open the lower enclosure door (if provided).
3. Separate the in-line disconnect plugs by squeezing the plugs. Do not pull on the harness wires. Label, tape, and disconnect wires to auxiliary contacts.

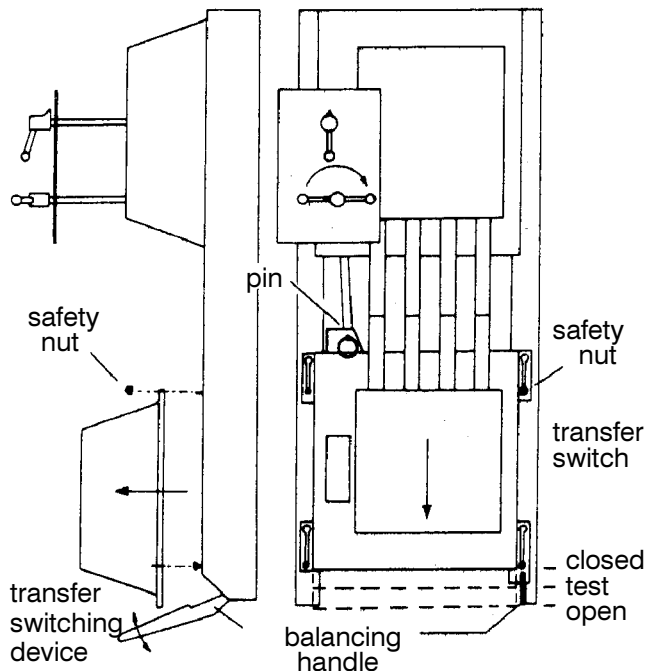

Figure 3-7. Transfer switch removal.

4. Remove the transfer switch as follows:

⚠ WARNING

Hold 150 lbs Transfer Switch firmly when removing safety retaining nut to prevent it from falling outward.

Pull out quick-disconnect pin to release linkage to Isolation Handle. Remove safety retaining nut from upper right mounting bushing. Push down spring-loaded balancing handle (right side) until bushings are at top of key-slots. Grasp back panel of transfer switch and pull it straight out. Do not lift at any other points (protect barriers). Then lift transfer switch out of cabinet. Transfer switch weighs about 150 lb.

5. Close the lower enclosure door (if provided).

TRANSFER SWITCH REINSTALLATION

This procedure explains how to install the transfer switching device after inspection and maintenance.

⚠ DANGER

Hazardous voltage capable of causing electrical shock, burns, or death is used in this ACTB. Do not touch any control circuit terminals.

1. Open the lower enclosure door (if provided).

⚠ CAUTION

All arc chutes and pole covers must be in place on the Transfer Switch.

⚠ CAUTION

The Transfer Switch contacts must be closed on the same source that is feeding the load (use manual handle).

2. Install the transfer switch by grasping the back pane and lifting it onto two support brackets extending outward. Press down balancing handle (right side) until slots accept the mounting bushings. Push panel flat against rails and secure it by lifting up handle. Install safety retaining nut (upper right corner). Position linkage from Isolation Handle between U-bracket on transfer switch (use handle to line up), then insert quick-disconnect pin and press ring flush. See Figure 3-8.

⚠ WARNING

Hold 150 lbs Transfer Switch firmly when installing safety retaining nut to prevent it from falling outward.

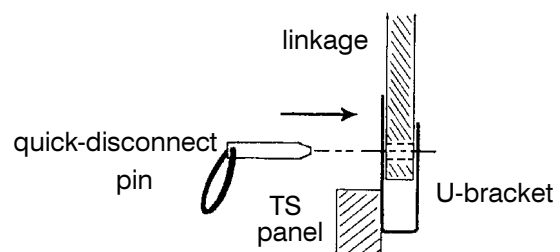

Figure 3-8. Transfer switch installation.

3. Reconnect the in-line disconnect plugs by grasping and pressing them together. Be sure to connect the correct plugs. Reconnect wires previously removed from auxiliary contacts.
4. Close the lower enclosure door (if provided).
5. Unlock the Isolation Handle. Carefully follow directions on page 3-3 to put the Isolation Handle in the *TEST* position, then the *CLOSE* position. Finally, follow directions on page 3-4 to put the Bypass Handle in the *AUTO* position.

BYPASSING & ISOLATING *(continued)*

RETURN TO SERVICE

This procedure explains how to return the automatic transfer switch to service after inspection and maintenance. Observe the *Transfer Switch Connected To* lights on the door.

1. Install the transfer switch into enclosure by carefully following directions on page 3-2.

⚠ WARNING

Close enclosure door to prevent personal injury in case of electrical system fault.

2. Turn **Isolation Handle** counterclockwise to the *TEST* position. (see Figure 3-9):

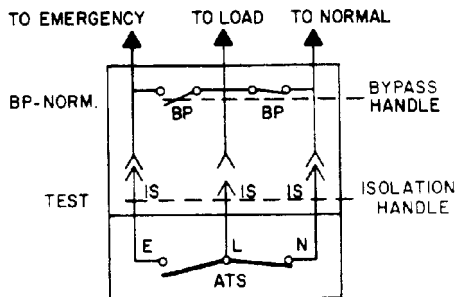

Figure 3-9. Test position.

Electrical Operation Test: This procedure will check the electrical operation of the automatic transfer switch without interrupting the load. It still should be Bypassed.

Perform the 5-step *Transfer Test* procedure on page 1-3.

The isolating contacts cannot be closed until the transfer switch is in the same position as the Bypass Switch.

3. Observe the position of the Bypass Handle. This position indicates the source that is bypassed.
4. Observe which *Transfer Switch Connected To* light is on (*Normal* or *Emergency*). This light indicates the position of the transfer switch. If it is not in the same position as the Bypass Switch, change transfer switching device position as follows.

To change the position of transfer switch

Operate to NORMAL	Operate to EMERGENCY
Turn Transfer Control switch counterclockwise to <i>Retransfer Delay Bypass</i> .	Turn Transfer Control switch clockwise to <i>Transfer Test</i> and hold.*
<i>Transfer Switch Connected to Normal</i> light should come on.	<i>Transfer Switch Connected to Emergency</i> light should come on.

* If Feature 2B time delay is used, there will be a delay of up to 5 minutes before transfer to Emergency.

NOTE: With Normal available, the automatic transfer switch will not stay in the emergency position unless Feature 3A time delay is used (at least 30 seconds).

⚠ WARNING

Do not close the isolating contacts unless the transfer switch and bypass switch are in the same position.

5. Push in and turn the **Isolation Handle** counterclockwise to the fully *CLOSED* position (Figure 3-10).

⚠ CAUTION

Align handle indicator. Do not leave the handle in an intermediate position.

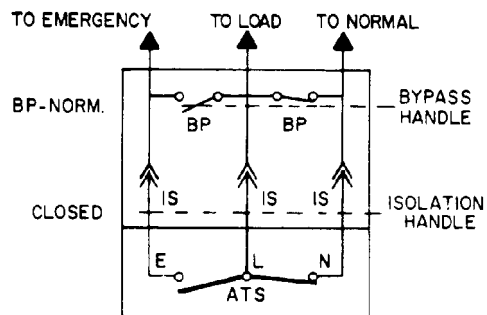

Figure 3-10. Closed position (Isolation contacts are fully engaged.)

6. Turn **Bypass Handle** to *AUTO* position (Figure 3-11).

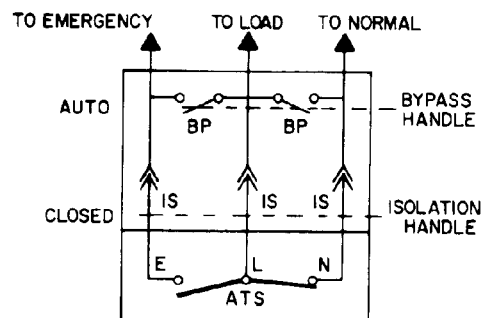

Figure 3-11. Auto position.

INDEX

A

Alarm Reset pushbutton, 1-3, 2-2
auxiliary circuits, 1-1

B

bypassing the ATS, 3-1

C

catalog number, cover
cleaning, 2-1
closed-transition transfer, 1-3
connections
 line, 1-1
control panel
 disconnecting, 2-1
 see *Control Panel User's Guide*

E

electrical operation, 1-3
Emergency Source Accepted light,
 1-2
engine starting contacts, 1-1
Extended Parallel Time light, 2-2

F

Failure to Synchronize light, 2-2
frequency, generator, 2-2
functional test, 1-2, 1-3

H

harness, 1-1
 disconnect plugs, 2-1

I

inspection, 3-1
installation, 1-1
isolating the ATS, 3-2

L

lights, 1-2, 1-3
load connected to emergency, 1-3
load connected to normal, 1-3
lubrication, 2-1

M

maintenance, preventive, 2-1
maintenance handle, 2-2
 warning, 2-2
manual load transfer, 2-2
 warning, 2-2

N

nameplate, cover
Normal Source Accepted light, 1-2

O

operation
 electrical, 1-3
 manual, 2-2
 warning, 2-2

P

parts, 2-1
phase rotation check, 1-2
preventive maintenance, 2-1
problem, 2-2

R

rating label, cover
replacement parts, 2-1
return to service, 3-3

S

service
 ASCO Services, Inc. (ASI), 2-1
settings
 see *Control Panel User's Guide*

T

test, functional, 1-2, 1-3
time delays, 2-1
 see *Control Panel User's Guide*
TS Locked Out light, 2-2
Transfer Control selector switch
 Retransfer Delay Bypass, 1-3
 Transfer Test, 1-3
Transfer Switch Connected To
 Emergency light, 1-3
Transfer Switch Connected To
 Normal light, 1-3
transfer test, 1-3, 2-1
transfer to emergency, 1-3, 2-1
transfer to normal, 1-3, 2-1
troubleshooting, 2-2

V

voltage checks, 1-2
voltage, pickup and dropout settings
 see *Control Panel User's Guide*