



GeneratorJoe

4016 Quartz Drive
Santa Rosa, CA 95405
Phone: 707 539-9003
Fax: 707 539-5212
Email: sales@generatorjoe.NET
Web www.generatorjoe.NET

FREEDOM LOAD BANK

100 KW

100 KW PORTABLE LOAD BANK

- Rated for Continuous Operation
- Compact, Portable, Easy to Transport and Operate
- Large Load Capacity – up to 100 KW
- Lightweight Aluminum and Aluminized Steel Enclosure with Casters
- Convenient Operator Controls with Digital Metering and Data Logging Software Included



QUALITY SYSTEM CERTIFIED TO
ISO 9001

The Avtron Freedom Load Bank is a portable, self-contained AC resistive load bank designed for indoor use. The load bank gives users the *freedom* of a high capacity load in an ultra compact package.

The load bank provides up to 100 KW resistive load at 480 VAC, 3-phase, 60 Hz and 93.75 KW at 240 VAC, 3-phase, 60 Hz.

Weighing only 105 pounds, this versatile load bank is less than half the weight and size of traditional load banks of similar capacity. The load bank features horizontal air discharge to provide a low profile design. Quick-connect load terminals and simple operation allow the load bank to be set up and operated by a single technician, saving valuable time in the field.

The load bank controls and cooling fans are powered by any standard 120 VAC, single-phase wall outlet with detachable line cord provided. An integral control panel is provided for load bank operation and includes the necessary controls and status indicators. The new standard in digital metering includes the Avtron Advanced Digital Monitoring System (ADMS)[™]. The ADMS meter provides faceplate digital display of Volts, Amps, Frequency, and KW. The Communicator EXT[™] Data Logging Software allows Real Time Data Acquisition and trending of all meter parameters from your Laptop PC or PDA. An Infrared/USB interface cable is included for "Plug and Play" convenience.

Legendary Avtron quality combined with simple operation and maintenance provide years of trouble free service.

The Avtron Freedom Load Bank is ideal for routine testing and maintenance of AC power sources such as stand-by emergency generators and UPS systems.

Avtron's extensive line of Load Bank and Industrial Resistor Products are solid performers used throughout the world.

For total technical support or additional information, please contact GeneratorJoe at (707) 539-9003 or sales@generatorjoe.net.

FREEDOM LOAD CAPACITY RATINGS

Total Load KW	Voltage Rating	Load Step Resolution KW
100 / 93.75	480 / 240 Volts AC 3 Phase, 60 Hz	5, 10, 10, 25, 50 / 3.75, 7.5, 7.5, 25, 50

FREEDOM LOAD BANK SPECIFICATIONS

CONSTRUCTION: A compact aluminized steel enclosure with screened inlet and exhaust openings houses the Freedom load bank. Four swivel casters provide mobility. Heavy duty lifting handles are also provided.

CONTROL POWER: The load bank requires control power of 120 VAC, 1-Phase, 60 Hz (line cord provided).

COOLING: The resistive elements are air-cooled by four high velocity muffin fans for quiet operation.

CONTROLS: The operator control panel includes a MASTER LOAD ON-OFF switch, load step ON-OFF industrial toggle switches, a BLOWER ON-OFF switch, and a LOAD VOLTAGE selector switch.

DIGITAL METERING: Avtron Advanced Digital Monitoring System (ADMS)[™] is provided for display of Volts, Amps,

Frequency, and KW. ADMS[™] also includes Communicator EXT[™] Data Logging Software.

SAFETY CIRCUITS: The Freedom load bank features main line circuit fusing, wrong voltage protection (dual voltage unit only), and overtemperature protection.

WEIGHT: Approximately 105 pounds [48 kg]

OPTIONS:

- 20 foot cable set with connectors
- Heavy Duty Shipping Case
- Designs for International 50/60 Hertz Voltages or Custom DC Designs are also available

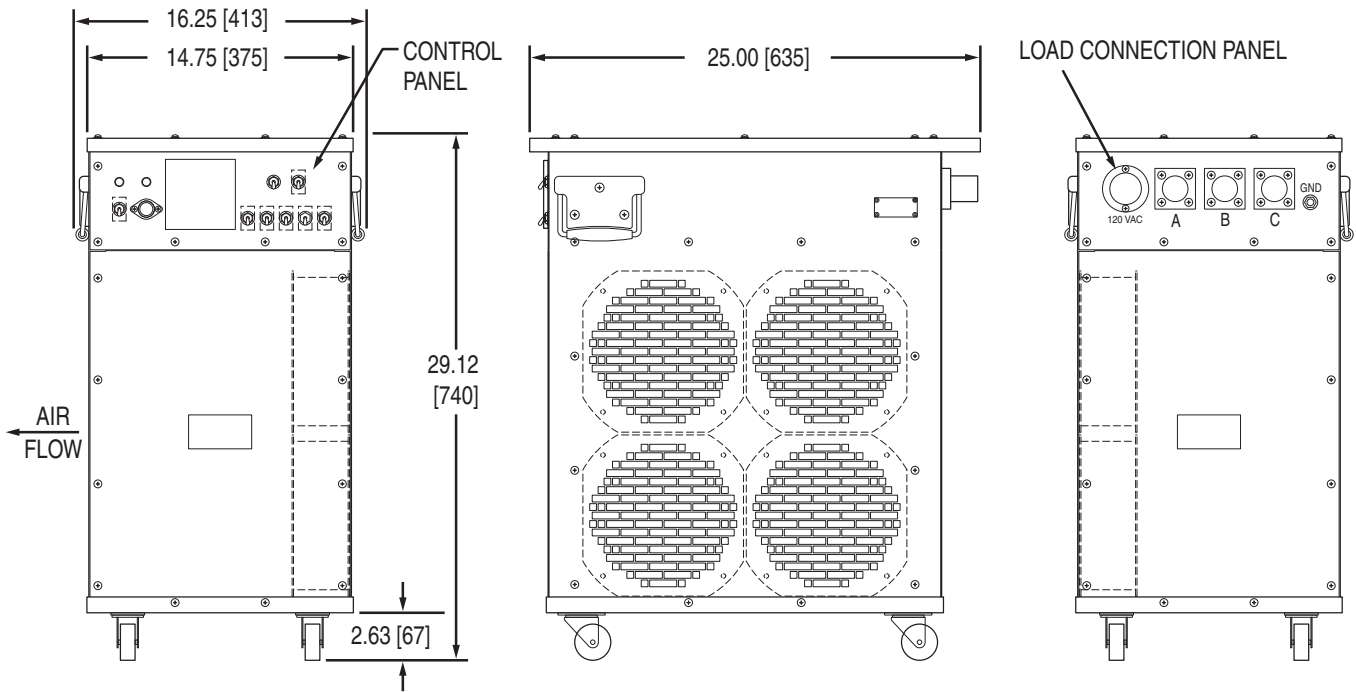

GeneratorJoe

4016 Quartz Drive
 Santa Rosa, CA 95405
 Phone: 707 539-9003
 Fax: 707 539-5212

Email: sales@generatorjoe.NET
 Web www.generatorjoe.NET



ADMS[™] is a trademark of Avtron Mfg., Inc.
 Communicator EXT[™] is a trademark of Electro Industries/GaugeTech.

All dimensions are in inches [millimeters].
 Specifications subject to change without notice.
 Printed in U.S.A. Rev. C