

# GeneratorJoe



4016 Quartz Drive  
Santa Rosa, CA 95405  
Phone: (707) 539-9003  
Fax: (707) 539-5212  
Email: sales@generatorjoe.NET  
Web: www.generatorjoe.NET

## HIGH CAPACITY TRAILER MOUNTED RESISTIVE LOAD BANK

1500 to 3000 KW

### MODEL LTV

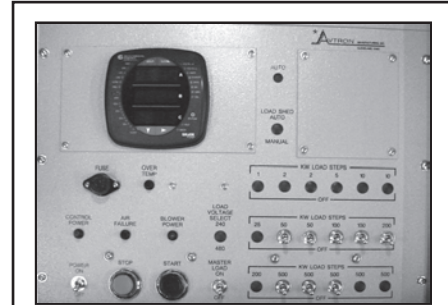

Operator Control Panel

QUALITY SYSTEM CERTIFIED TO  
**ISO 9001**

- High Capacity in a Single Package
- Heavy Duty Dual Axle Trailer
- Travel/Storage Cover Included
- Convenient Operator Controls with Digital Metering and Data Logging Software Included
- Optional Hand Held Remote Controller

# T

he Avtron Model LTV load bank is designed for very high power testing of large diesel generating systems, Uninterruptible Power Supplies (UPS), engine generator sets or turbines.

Previously, trailer mounted load banks were limited to about 1250 KW maximum. The extra high capacity of the LTV load bank in a single mobile package eliminates the need to transport multiple load banks to a job site, saving both time and money.

The new standard in Digital Metering includes the Avtron Advanced Digital Monitoring System (ADMS™). The ADMS meter provides faceplate Digital display of Volts, Amps, Frequency, and Power measurements. The Communicator EXT™ Data Logging Software allows Real Time Data Acquisition and trending of all meter parameters from your Laptop PC or PDA. An Infrared/USB interface cable is included for "Plug and Play" convenience.

Legendary Avtron quality combined with simple operation and maintenance provide years of trouble free service.

*The Model LTV trailer mounted load bank is ideal for high power mobile testing of AC generating systems at multiple sites.*

*Avtron's extensive line of Load Bank and Industrial Resistor Products are solid performers used throughout the world.*

*For total technical support or additional information, please contact GeneratorJoe at (707) 539-9003 or sales@generatorjoe.net*

## LTV LOAD CAPACITY RATINGS

Model	Total Load KW	Voltage	Minimum Load Step Resolution KW
LTV - 1500	1500	480 VAC, 3 PH, 60 Hz	5 or 50
LTV - 2000	2000	480 VAC, 3 PH, 60 Hz	5 or 50
LTV - 2500	2500	480 VAC, 3 PH, 60 Hz	5 or 50
LTV - 3000	3000	480 VAC, 3 PH, 60 Hz	5 or 50

Other voltages and KW ratings are available. Consult factory.

## LTV SPECIFICATIONS

**CONSTRUCTION:** The load bank enclosure is made of heavy gauge aluminized steel with polyurethane enamel paint. Vertical airflow directs hot exhaust air away from ground level and provides extra safety in an outdoor environment. The trailer features heavy duty welded construction with steel deck, dual axles, leaf spring suspension, 10,000 lbs. GVW, DOT approved. Electric brakes, 3" adjustable lunette eye, safety chains, and stabilizer jacks are provided.

**RESISTOR ELEMENTS:** The resistive elements are designed by Avtron and manufactured of a corrosion resistant chromium alloy wire. Resistive elements are fully supported over their entire length with stainless steel rods for improved operating life.

**CONTROLS:** The controls and digital metering are housed in a single NEMA enclosure including a POWER ON-OFF switch, a POWER ON light, FAN ON-OFF push buttons with a FAN FAILURE light, OVERTEMPERATURE light, MASTER LOAD ON-OFF switch, PHASE ROTATION switch, and individual load step switches.

**DIGITAL METERING:** Avtron Advanced Digital Monitoring System (ADMS™) is provided for display of Volts, Amps, Frequency, and KW. ADMS™ also includes Communicator EXT™ Data logging Software

**COOLING:** The resistive elements are air cooled by multiple self-contained 10 HP fans rated at 460 volts, 3-phase,

60 Hz. No additional cooling period is required when load is removed.

**SAFETY CIRCUITS:** The LTV load bank features branch circuit fusing on all load steps. Motor overload protection, overtemperature protection, and cooling air loss protection are also provided.

**WEIGHT:** 6000 - 8000 pounds [2700 - 3600 kg] (depending on rating).

### STANDARD FEATURES:

- Local metering and control panel with enclosure
- Heavy duty vinyl storage and travel cover with tie downs
- Control Power Transformer Rated 480 Volts to 120 Volts, 1-Phase, 60 Hz

### OPTIONAL FEATURES:

- Dual voltage blower and control power transformer
- Hand held remote control unit
- Hydraulic Surge Brakes
- Cable Storage Reels

**NOTE:** Refer to Operation and Maintenance Manual for safe towing instructions.

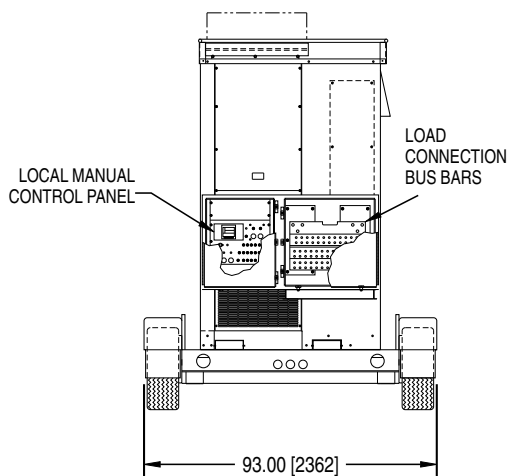

2000 KW unit shown.

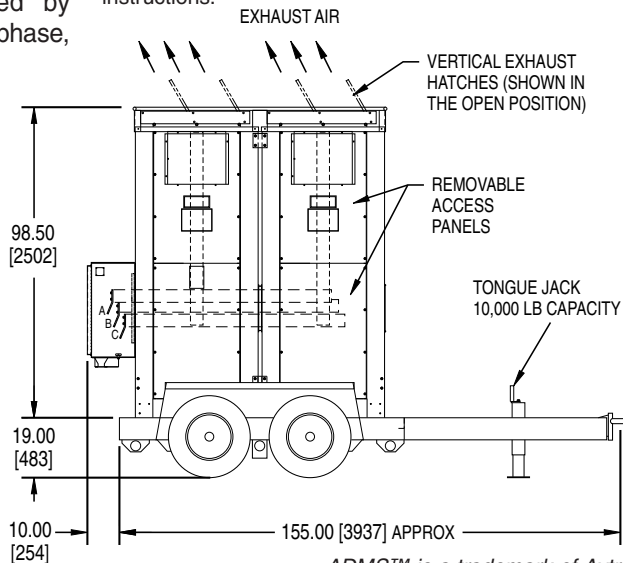

ADMS™ is a trademark of Avtron Mfg., Inc.  
Communicator EXT™ is a trademark of Electro Industries/GaugeTech.

All dimensions are in inches [millimeters].  
Specifications subject to change without notice.  
Printed in U.S.A. Rev. B

# GeneratorJoe



4016 Quartz Drive  
Santa Rosa, CA 95405  
Phone: (707) 539-9003  
Fax: (707) 539-5212  
Email: sales@generatorjoe.NET  
Web: www.generatorjoe.NET