

NOTES:  
 FOR GEN-SET MODEL TYPES BCY 20P, BCY22P  
 & BCY17PSP  
 ENGINE TYPE: YANMAR 4TNE 84/88  
 ALTERNATOR TYPE: NEWAGE BC1184  
 RADIATOR TYPE: WITH ENGINE



**GeneratorJoe**

4016 Quartz Drive  
 Santa Rosa, CA 95405  
 Phone: 707 539-9003  
 Fax: 707 539-5212  
 Email: sales@generatorjoe.NET  
 Web www.generatorjoe.NET

GENERATOR TO BE PLACED DIRECTLY ON  
 TO A FLAT AND LEVEL FLOOR OR CONCRETE  
 BASE.

SHIPPING WEIGHT: = 430 kg

WET WEIGHT  
 (WITH OIL, COOLANT AND FUEL): = 490 kg

TOTAL ENGINE OIL  
 CAPACITY (WITH FILTERS): 5.8 LITRES

COOLING SYSTEM CAPACITY  
 (50/50 WATER/GLYCOL): 12 LITRES

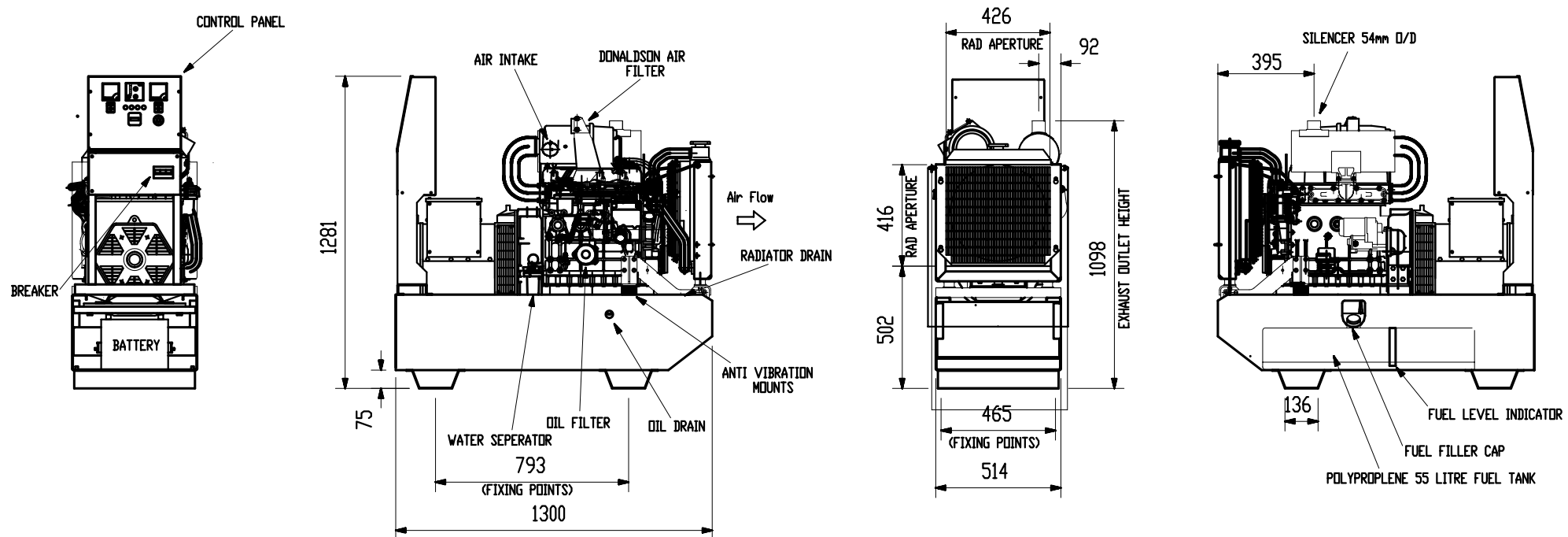

THE FIXING POINTS ARE 4 OFF 12mm Ø HOLES,  
 WE RECOMMEND THAT WHEN A GENERATOR IS  
 INSTALLED THAT THE FIXING POINTS ARE USED

ISS	ALTERATIONS	DATE
C	POSITION OF EXHAUST OUTLET CORRECTED (395 WAS 695)	28-07-03
D	FIXING CENTRES ALTERED TO 464mm	29-07-03

NOTES

TOLERANCES:  
 BETWEEN HOLE CENTRES & HOLE CENTRE TO EDGE (ON FLAT) ± 0.2

HOLE CENTRES TO BEND AND EDGES TO BEND ± 0.5

ACROSS EACH BEND ± 0.5

FABRICATION ± 1.0

HOLE DIAMETERS AND SLOT WIDTHS +0.1, -0.0

ANGULAR ± 0.5°

THIRD ANGLE PROJECTION  
 DO NOT SCALE, IF IN DOUBT ASK

DISTRIBUTION	
MASTER	FABRICATOR
TITLE:	YANMAR 4 CYL GENSET
CLIENT:	
SITE:	
W.O. No.:	ENGINEER: NJ
TYPE:	YANMAR CHECKED:
SCALE:	1:20 DATE:
TOTAL No. OF SHEETS: 1	
DRAWING NO.	ISSUE
YOS002GA	D
<b>BROADCROWN</b>	