

FOR INDIVIDUAL GEN-SET MODEL TYPES SEE
BROADCROWN LITERATURE

ENGINE TYPE: MITSUBISHI S4S
ALTERNATOR: BCI 184G

SHIPPING WEIGHT
(WITH OIL): TBC

WET WEIGHT
GLYCOL & FUEL: TBC

OIL CAPACITY: 10 LITRES
COOLING CAPACITY: 9.0 LITRES
FUEL TANK CAPACITY: 95 LITRES (USABLE)

GENERATOR IS TO BE PLACED ON A FLAT
FLOOR OR CONCRETE BASE

PLEASE NOTE WEIGHTS MAY VARY
DEPENDING ON ALTERNATOR COMBINATION

THIS DRAWING IS A PROTOTYPE. THE
DESIGN MAY VARY SLIGHTLY TO THE FINAL
PRODUCTION UNIT.



GeneratorJoe

4016 Quartz Drive
Santa Rosa, CA 95405
Phone: 707 539-9003
Fax: 707 539-5212
Email: sales@generatorjoe.NET
Web www.generatorjoe.NET

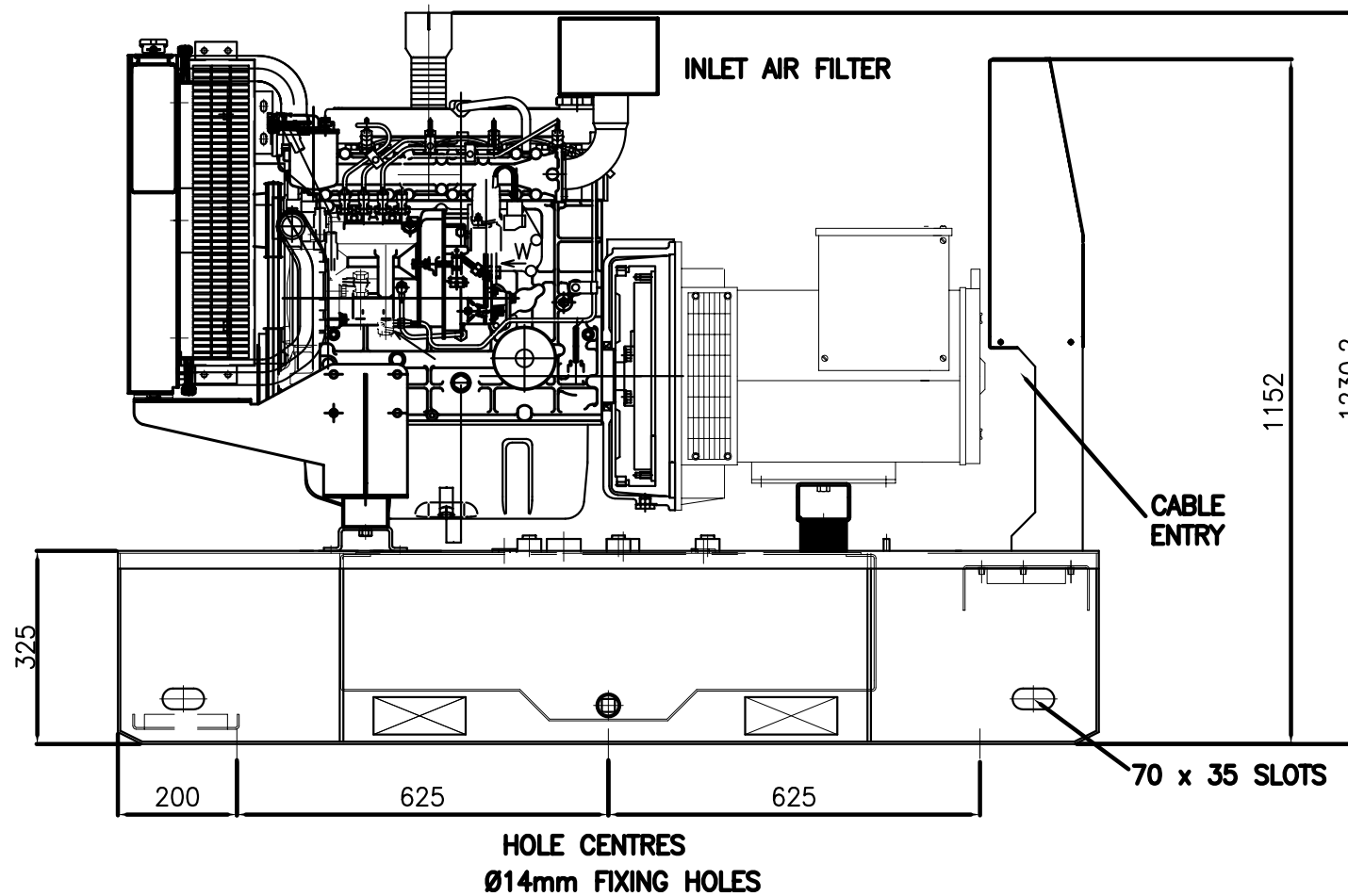
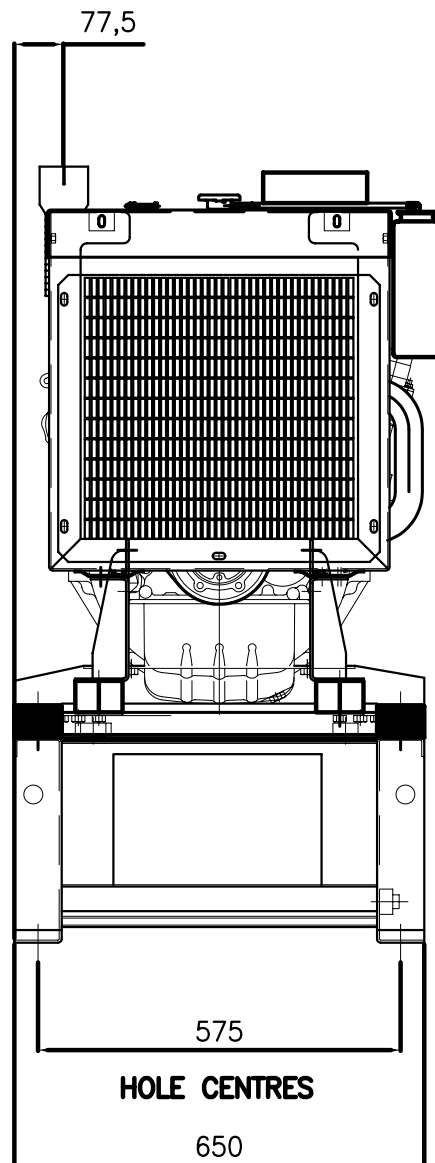
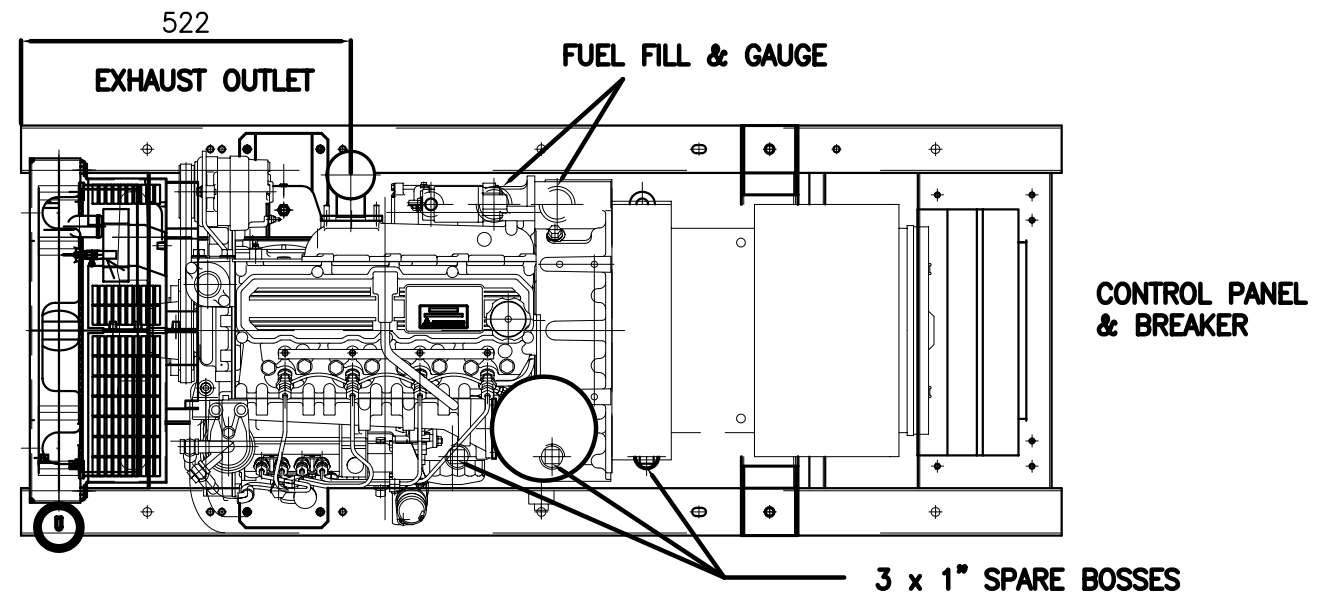

ISS	ALTERATIONS	DATE

NOTES

TOLERANCES:
BETWEEN HOLE CENTRES & HOLE
CENTRE TO EDGE (ON FLAT) ± 0.2

HOLE CENTRES TO BEND AND
EDGES TO BEND ± 0.5

ACROSS EACH BEND ± 0.5

FABRICATION ± 1.0

HOLE DIAMETERS AND SLOT
WIDTHS +0.1, -0.0

ANGULAR ± 0.5°

THIRD ANGLE PROJECTION
DO NOT SCALE, IF IN DOUBT ASK

DISTRIBUTION	
MASTER	FABRICATOR
TITLE:	S4S OPEN SET ARRANGEMENT
CLIENT:	N/A
SITE:	N/A
W.O. No.:	N/A ENGINEER: A.ROBERTS
TYPE:	S4S CHECKED:
SCALE:	1:16 DATE:
TOTAL No. OF SHEETS: 1	
DRAWING NO.	ISSUE
MGA008	A
BROADCROWN	