

FOR INDIVIDUAL GEN-SET MODEL TYPES SEE BROADCAST LITERATURE.

ENGINE TYPE: 3029TF  
ALTERNATOR: BCI 184  
(BCI 184 J ILLUSTRATED)

USABLE FUEL CAPACITY: 105L

SHIPPING WEIGHT  
(WITH OIL): 985Kg

WET WEIGHT  
50/50 GLYCOL & FUEL: 1090Kg

OIL CAPACITY: 9 LITRES  
COOLING CAPACITY: 14.5 LITRES

GENERATOR IS TO BE PLACED ON A FLAT FLOOR OR CONCRETE BASE

PLEASE NOTE WEIGHTS MAY VARY DEPENDING ON ALTERNATOR COMBINATION



**GeneratorJoe**

4016 Quartz Drive  
Santa Rosa, CA 95405  
Phone: 707 539-9003  
Fax: 707 539-5212  
Email: sales@generatorjoe.NET  
Web www.generatorjoe.NET

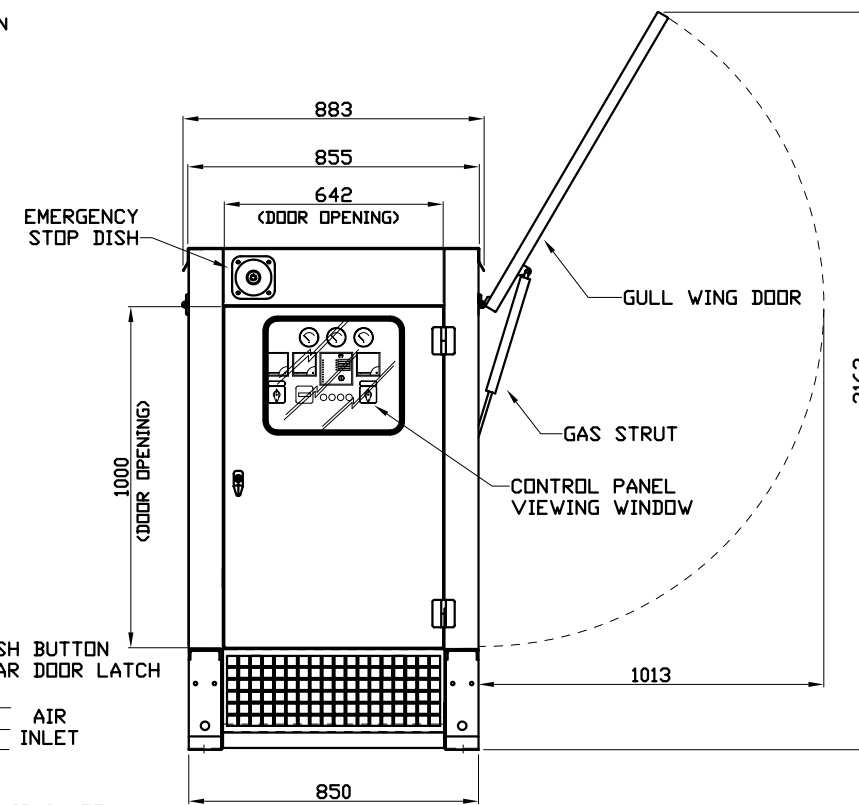
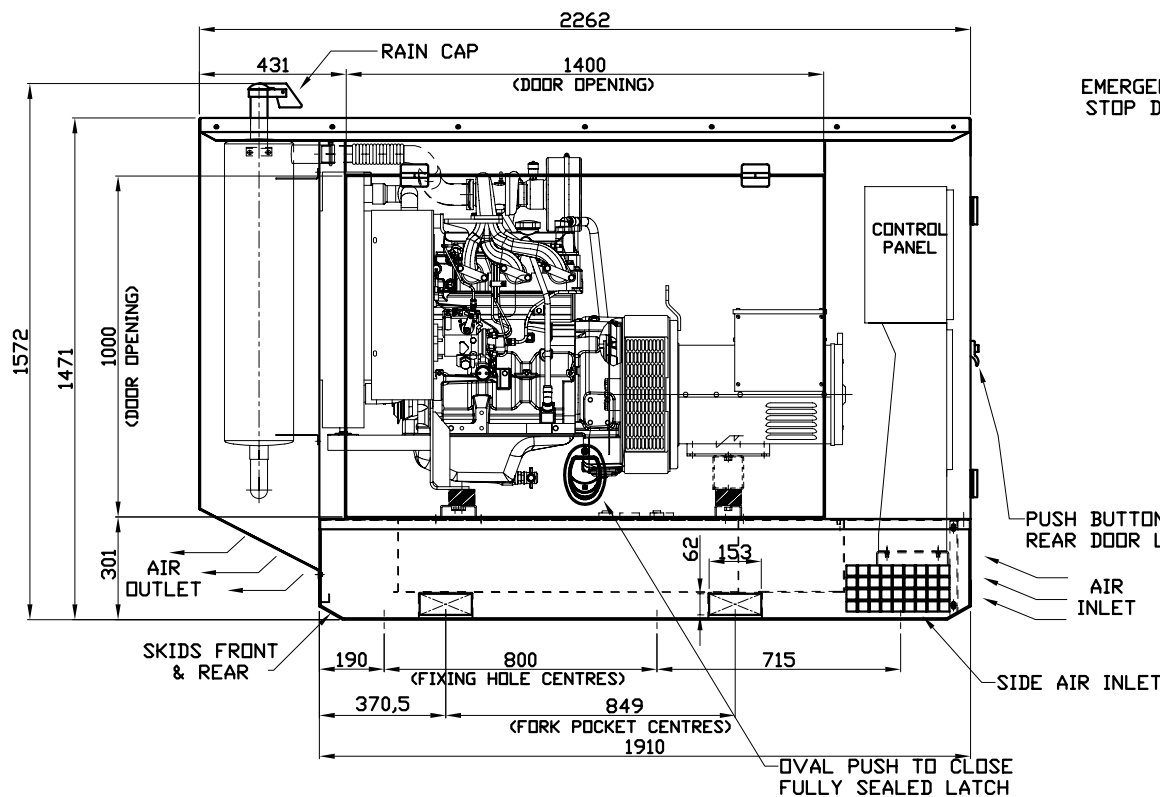
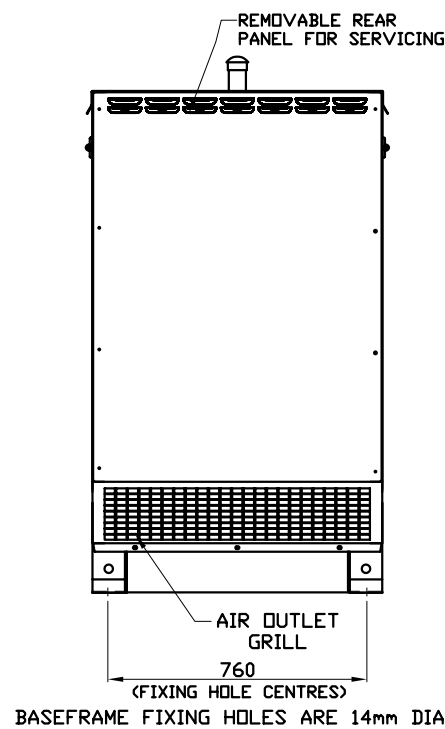
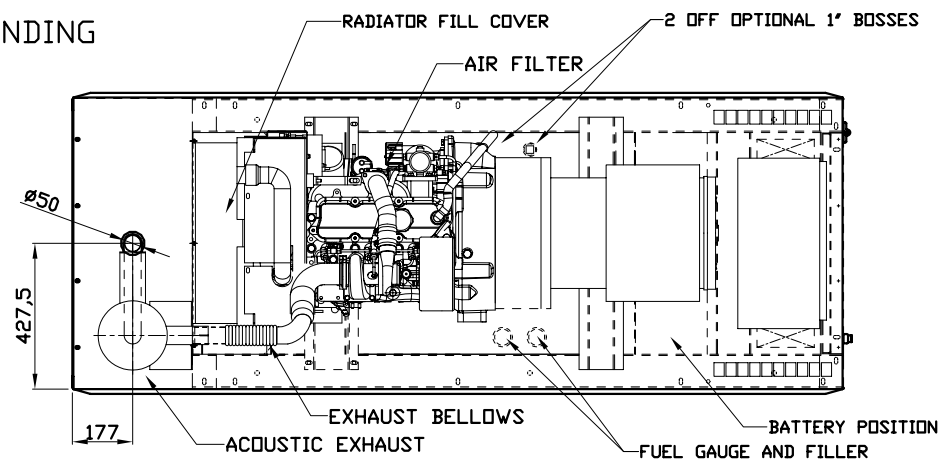

ISS	ALTERATIONS	DATE
B	BATTERY POSITION MOVED.	04-04-06 P.R

NOTES

TOLERANCES:  
BETWEEN HOLE CENTRES & HOLE CENTRE TO EDGE (ON FLAT) ± 0.2

HOLE CENTRES TO BEND AND EDGES TO BEND ± 0.5

ACROSS EACH BEND ± 0.5

FABRICATION ± 1.0

HOLE DIAMETERS AND SLOT WIDTHS +0.1, -0.0

ANGULAR ± 0.5°

THIRD ANGLE PROJECTION  
DO NOT SCALE, IF IN DOUBT ASK

DISTRIBUTION	
MASTER	FABRICATOR
TITLE:	JD 3029TF ACOUSTIC CANOPY 1
CLIENT:	
SITE:	
W.O. No.:	ENGINEER: P.RUTTER
TYPE:	CHECKED:
SCALE:	DATE:
TOTAL No. OF SHEETS: 1	
DRAWING NO.	ISSUE
JGA042	B
<b>BROADCAST</b>	