

FOR INDIVIDUAL GEN-SET MODEL TYPES  
SEE BROADCAST LITERATURE.

ENGINE TYPE: 4045TF  
ALTERNATOR: UCI 224 G

USABLE FUEL CAPACITY: 225L

SHIPPING WEIGHT  
(WITH OIL): 1530Kg

WET WEIGHT  
50/50 GLYCOL & FUEL: 1750Kg

OIL CAPACITY: 12 LITRES  
COOLING CAPACITY: 25 LITRES

GENERATOR IS TO BE PLACED ON A FLAT  
FLOOR OR CONCRETE BASE

PLEASE NOTE WEIGHTS MAY VARY  
DEPENDING ON ALTERNATOR COMBINATION



**GeneratorJoe**

4016 Quartz Drive  
Santa Rosa, CA 95405  
Phone: 707 539-9003  
Fax: 707 539-5212  
Email: sales@generatorjoe.NET  
Web www.generatorjoe.NET

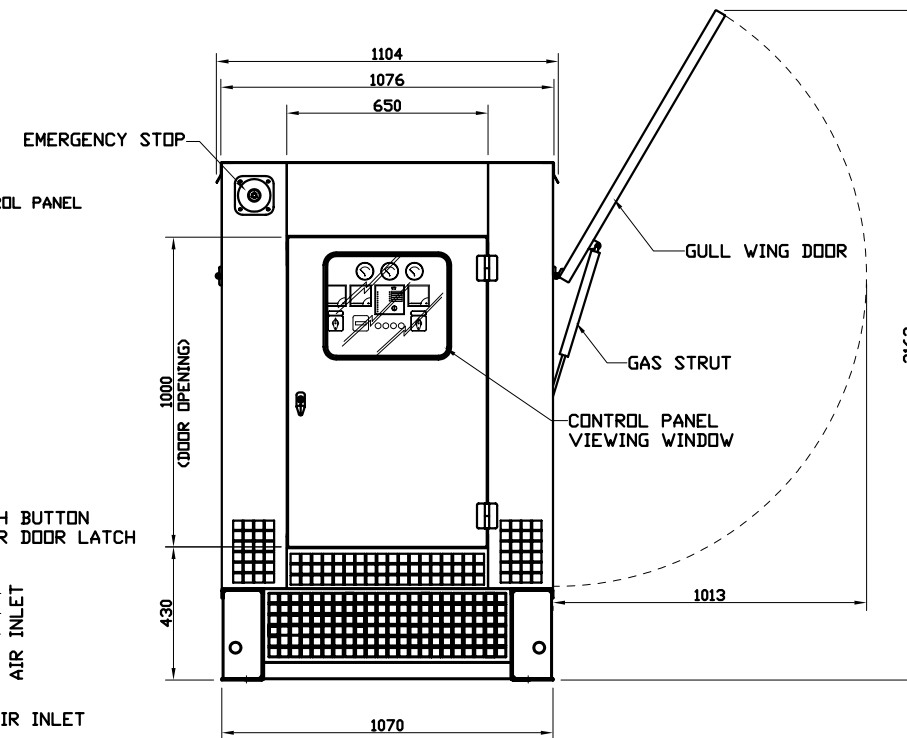
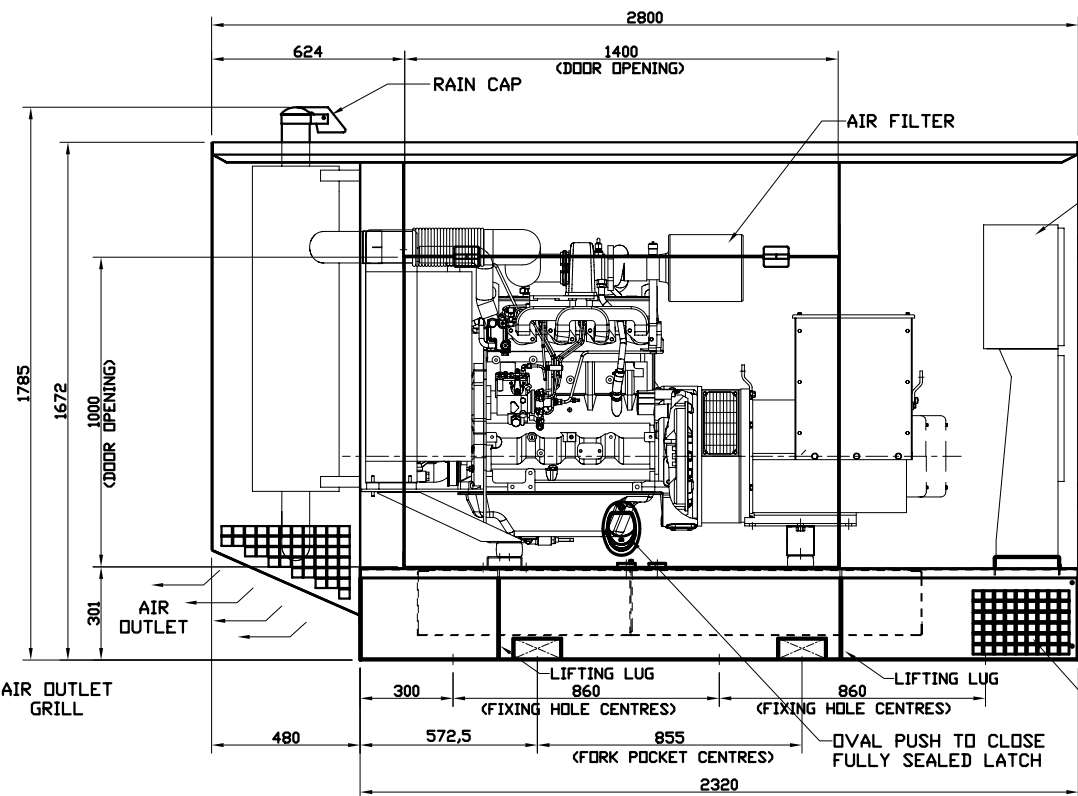
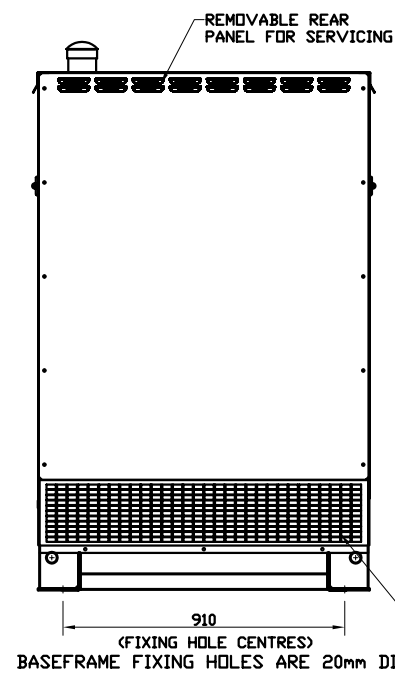
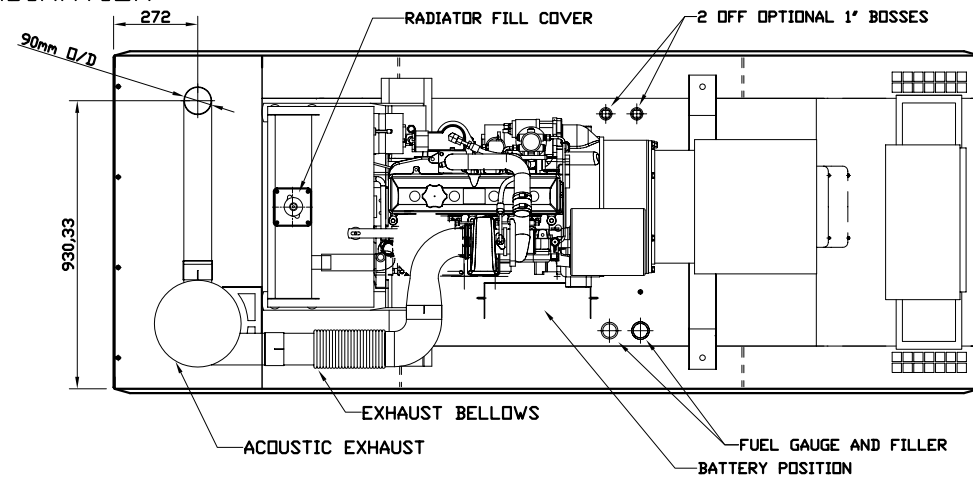

ISS	ALTERATIONS	DATE
B	EMERGENCY STOP DISH MOVED. MORE DETAIL ADDED.	27-10-03 N.J
C	FUEL CAPACITY CORRECTED, WEIGHTS ADJUSTED.	15-01-04 P.R

NOTES

TOLERANCES:  
BETWEEN HOLE CENTRES & HOLE CENTRE TO EDGE (ON FLAT) ± 0.2

HOLE CENTRES TO BEND AND EDGES TO BEND ± 0.5

ACROSS EACH BEND ± 0.5

FABRICATION ± 1.0

HOLE DIAMETERS AND SLOT WIDTHS +0.1, -0.0

ANGULAR ± 0.5°

THIRD ANGLE PROJECTION  
DO NOT SCALE, IF IN DOUBT ASK

DISTRIBUTION	
MASTER	FABRICATOR
TITLE:	JD 4045TF ACOUSTIC CANOPY 2
CLIENT:	
SITE:	
W.O. No.:	ENGINEER: N JONES
TYPE:	CHECKED:
SCALE:	DATE:
TOTAL No. OF SHEETS: 1	
DRAWING NO.	ISSUE
JGA004	C
<b>BROADCAST</b>	