

GENSET DETAILS--
 BCC2000S-60-T2
 ENGINE: CUMMINS QSK60 G12
 ALTERNATOR: NEWAGE PI 734F (SINGLE BEARING)
 RADIATOR: BEARWARD 5684100001
 AV MOUNTS: AVA 4014 SERIES

WEIGHTS:-
 ENGINE: 7185 KG DRY, 7540 KG WET
 ALTERNATOR: 3840 KG
 RADIATOR: 1780 KG DRY, 2161 KG WET

TOTAL GENERATOR WEIGHT: 16115 KG (DRY), 16850 KG (WET)

COLOURS:-
 ENGINE:- MAIZE YELLOW
 BASEFRAME, ALTERNATOR & RADIATOR:- SEMI GLOSS BLACK

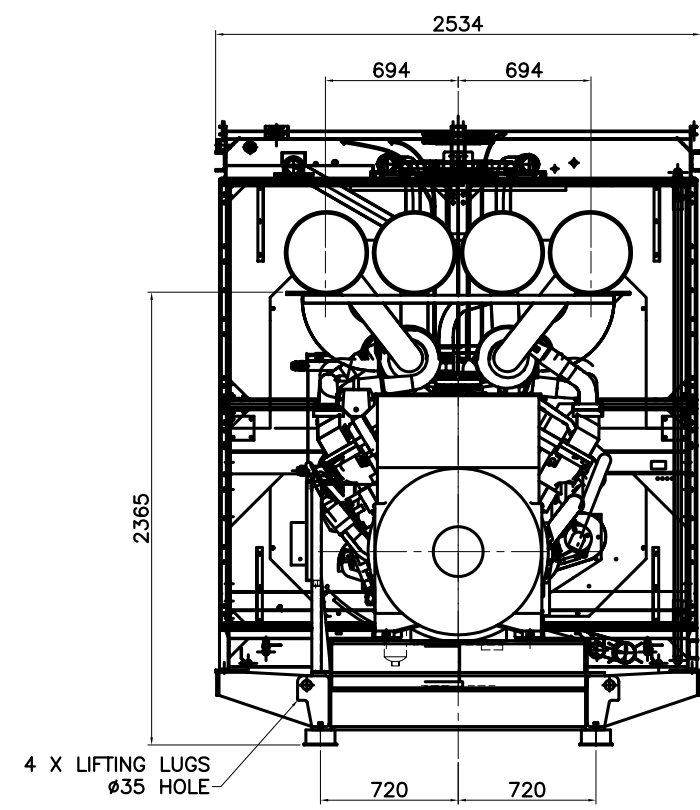
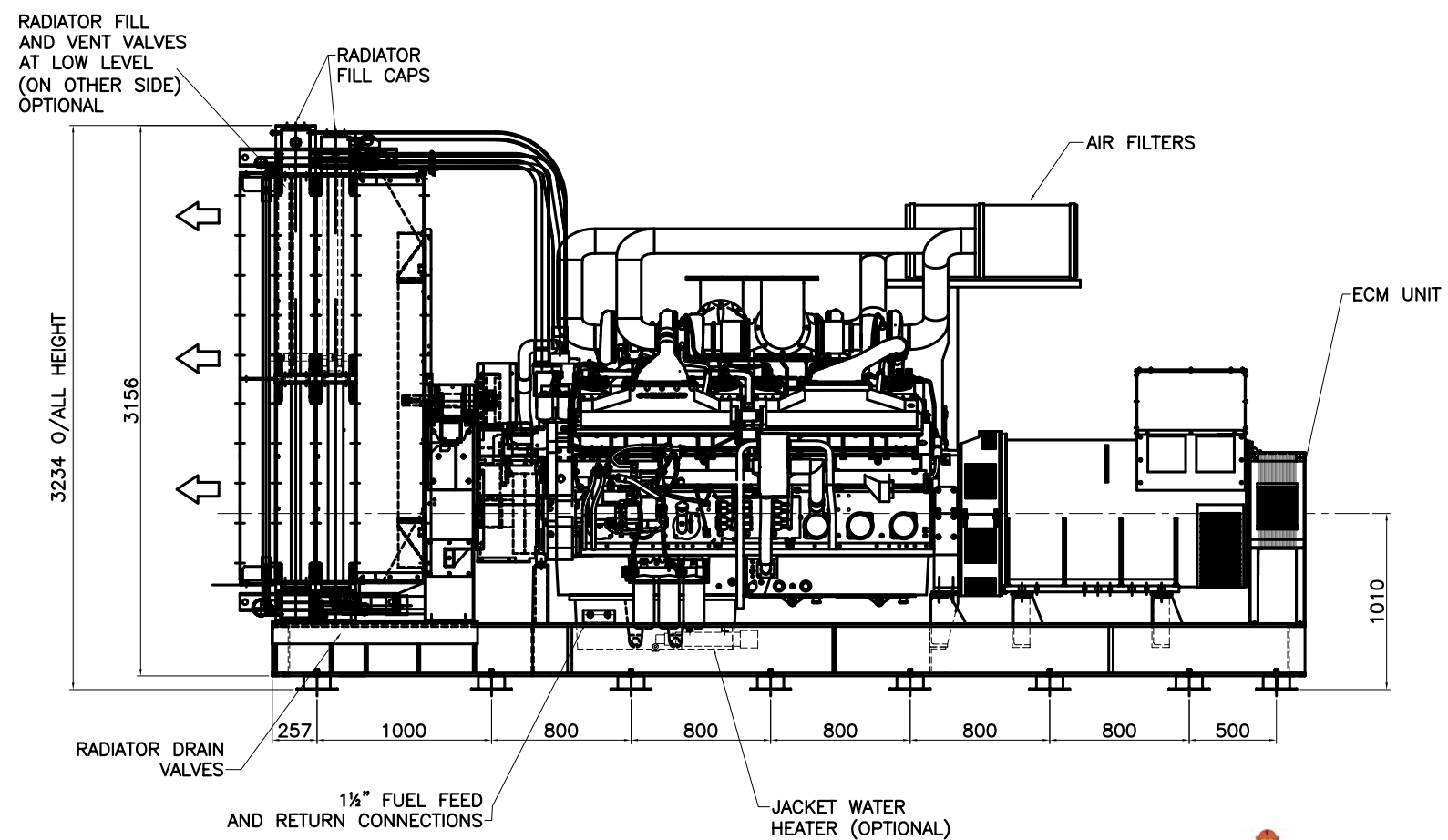
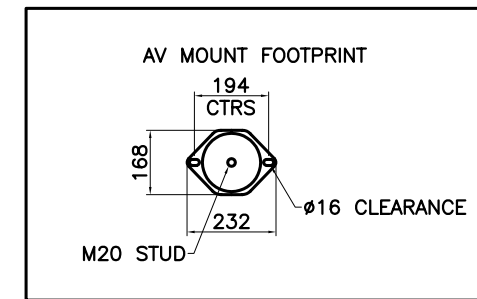

No. ALTERATIONS CHK'D DATE

NOTES - MECHANICAL

TOLERANCES:
 GENERAL TOLERANCE + / - 5MM
 FABRICATION + / - 3MM
 HOLE CENTRES + / - 1MM
 OTHER TOLERANCES AS STATED WHERE REQUIRED

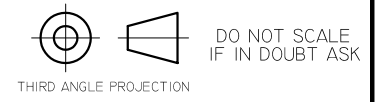

TITLE: GEN-SET GENERAL ARRANGEMENT

CLIENT: -

SITE: -

W.O. No.: - ENGINEER: -

TYPE: BCC2000S-60-T2 DRAWN BY: -

SCALE: NTS DATE: -

TOTAL No. OF SHEETS (1 - 999) 1

DRAWING NO. ISSUE

BCC2000-GA01-AI A



GeneratorJoe

4016 Quartz Drive
 Santa Rosa, CA 95405
 Phone: 707 539-9003
 Fax: 707 539-5212
 Email: sales@generatorjoe.NET
 Web www.generatorjoe.NET