

FOR INDIVIDUAL GEN-SET MODEL TYPES SEE BROADCROWN LITERATURE.

ENGINE TYPE: 6090HF
 ALTERNATOR: UCI 274/HCI 444
 (HCI 444 D ILLUSTRATED)

USEABLE FUEL CAPACITY: 820L

SHIPPING WEIGHT
 (WITH OIL): TBC

WET WEIGHT
 50/50 GLYCOL & FUEL:

OIL CAPACITY: TBC LITRES
 COOLING CAPACITY: 67.0 LITRES

GENERATOR IS TO BE PLACED ON A FLAT FLOOR OR CONCRETE BASE.

PLEASE NOTE WEIGHTS MAY VARY DEPENDING ON ALTERNATOR COMBINATION.



GeneratorJoe

4016 Quartz Drive
 Santa Rosa, CA 95405
 Phone: 707 539-9003
 Fax: 707 539-5212
 Email: sales@generatorjoe.NET
 Web www.generatorjoe.NET

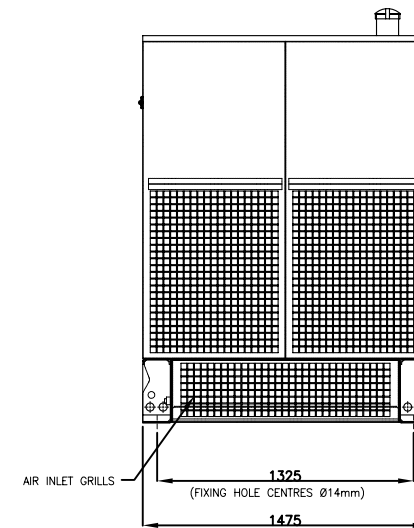
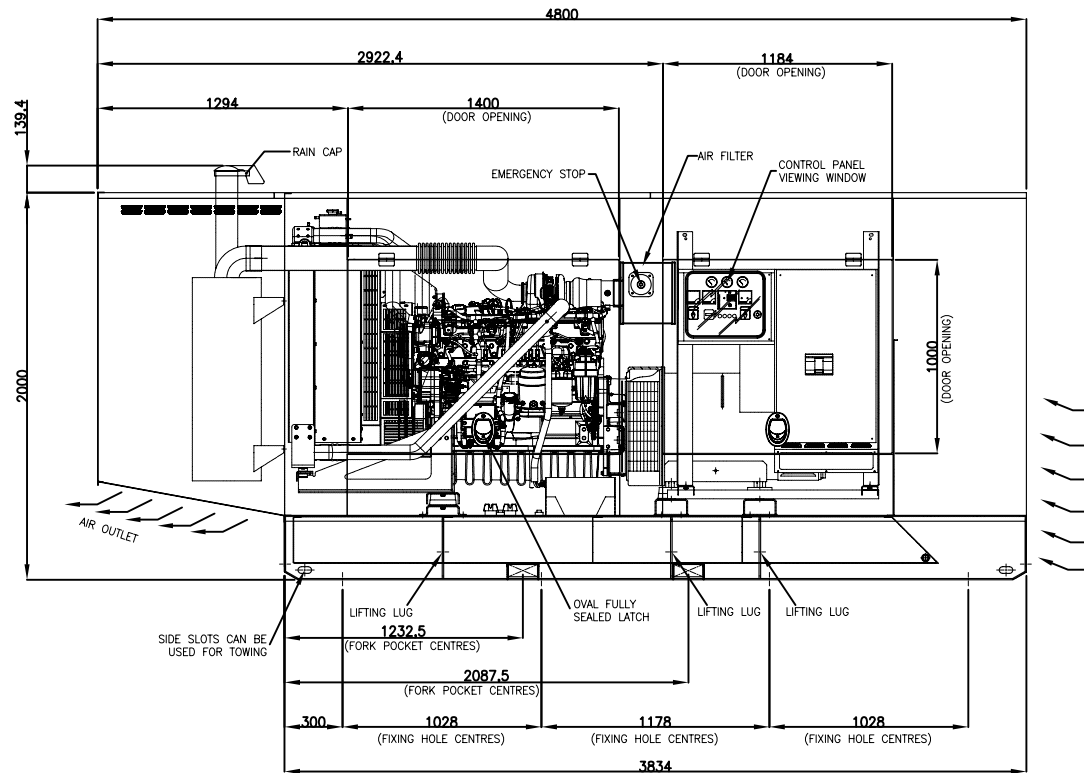
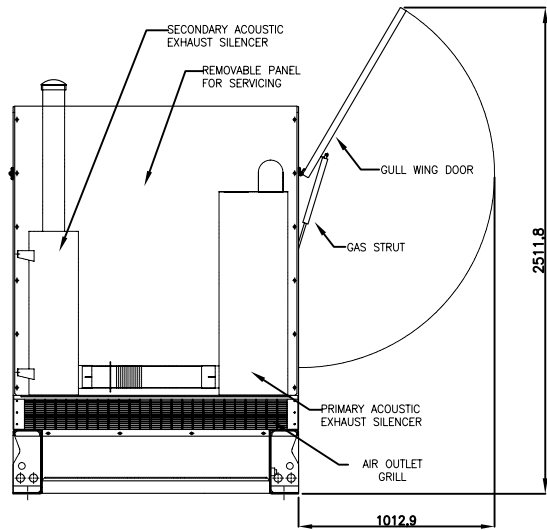
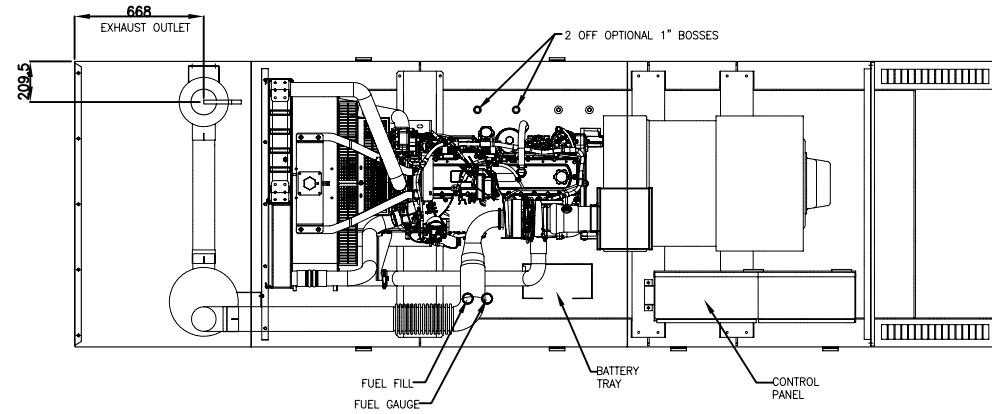

ISS	ALTERATIONS	DATE

NOTES

TOLERANCES:
 BETWEEN HOLE CENTRES & HOLE CENTRE TO EDGE (ON FLAT) ± 0.2

HOLE CENTRES TO BEND AND EDGES TO BEND ± 0.5

ACROSS EACH BEND ± 0.5

FABRICATION ± 1.0

HOLE DIAMETERS AND SLOT WIDTHS +0.1, -0.0

ANGULAR ± 0.5°

THIRD ANGLE PROJECTION
 DO NOT SCALE, IF IN DOUBT ASK

DISTRIBUTION	
MASTER	FABRICATOR

TITLE:	JD 6090HF 485 ACOUSTIC CANOPY		
CLIENT:			
SITE:			
W.O. No.:	ENGINEER:	P.RUTTER	
TYPE:	JD 6090HF485	CHECKED:	
SCALE:	1:40	DATE:	

TOTAL No. OF SHEETS: 1	
DRAWING NO.	ISSUE
JGA049	A

BROADCROWN