

GENSET DETAILS—  
 ENGINE: CUMMINS QSK23 G3  
 ALTERNATOR: NEWAGE HCI 634G (SINGLE BEARING)  
 RADIATOR: BEARWARD 56703  
 A.V. MOUNTS: FARRAT ISOLATOR RM SERIES  
 FRONT ENGINE FEET: AVM-R11255BN6  
 REAR ENGINE AND ALTERNATOR FEET: AVM-R10055BN7  
 OUTPUT: 800 kVA @ 1500 RPM (PRIME RATING)  
 OUTPUT: 850 kVA @ 1500 RPM (STANDBY RATING)  
 WEIGHTS:—  
 ENGINE: 2755 KG DRY, 2805 KG WET  
 ALTERNATOR: 2113 KG  
 RADIATOR: 400 KG DRY, 460 KG WET

COLOURS:—  
 ENGINE :- MAIZE YELLOW  
 ALTERNATOR, BASEFRAME & RADIATOR:— SEMI GLOSS BLACK



**GeneratorJoe**

4016 Quartz Drive  
 Santa Rosa, CA 95405  
 Phone: 707 539-9003  
 Fax: 707 539-5212  
 Email: sales@generatorjoe.NET  
 Web www.generatorjoe.NET

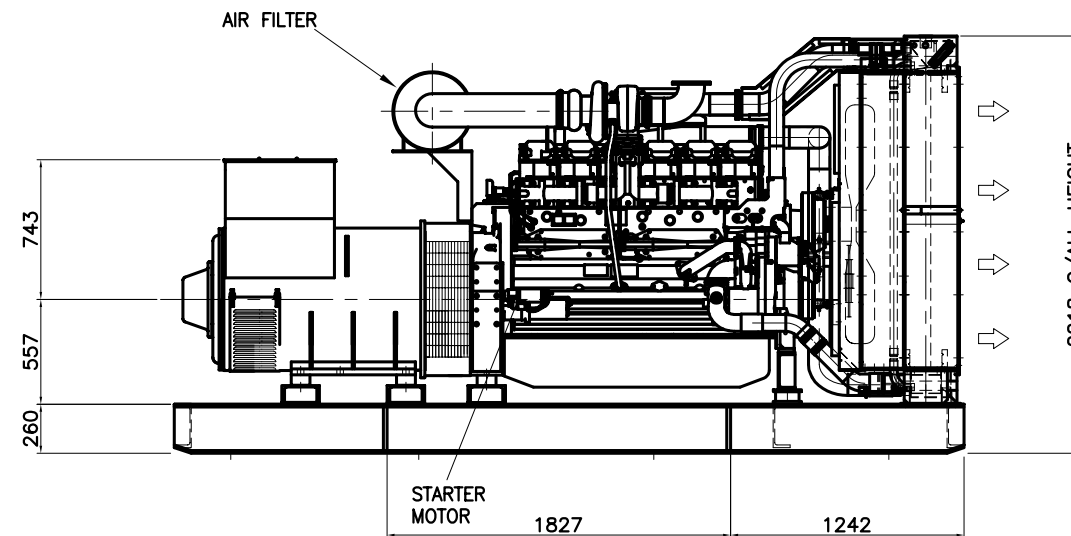
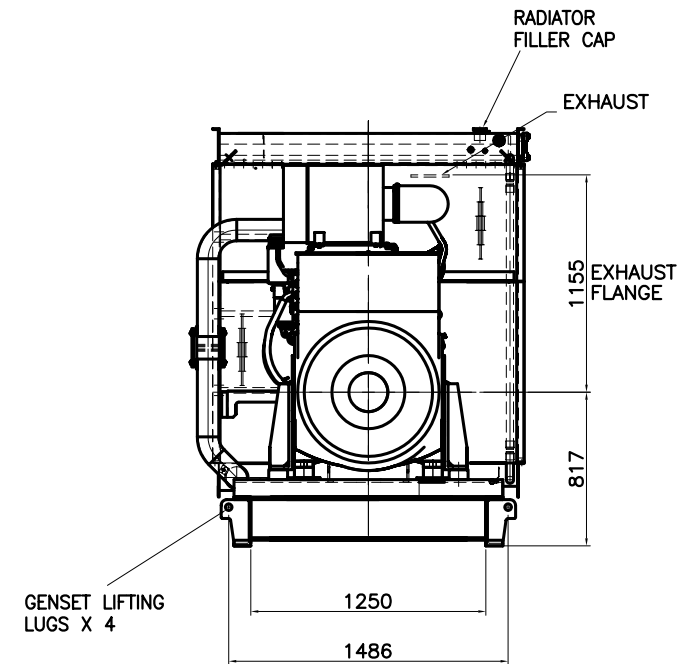
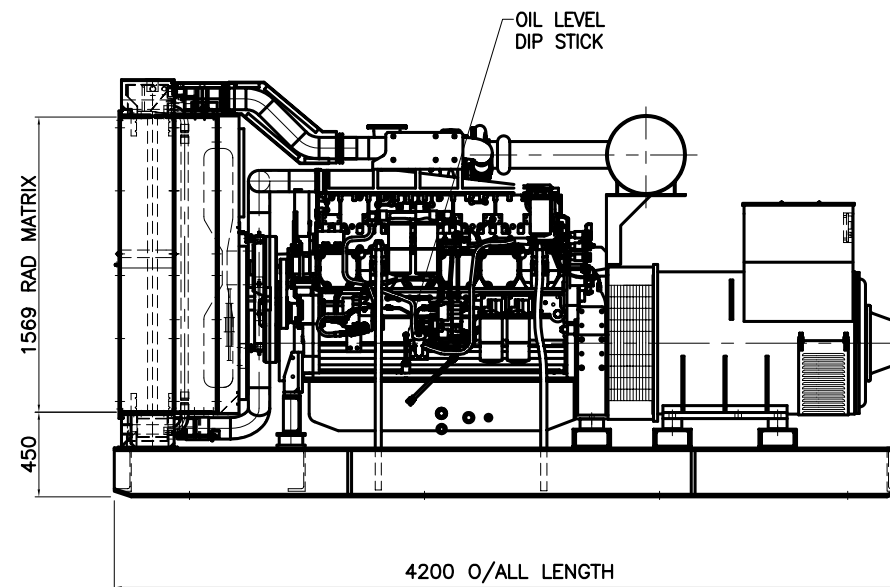
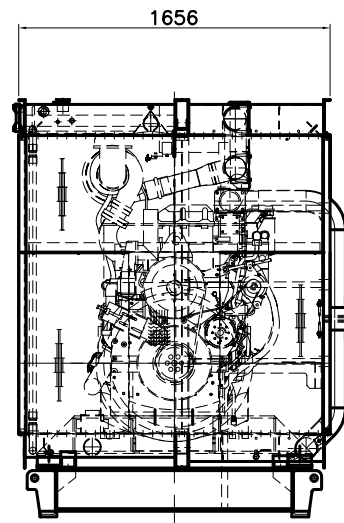
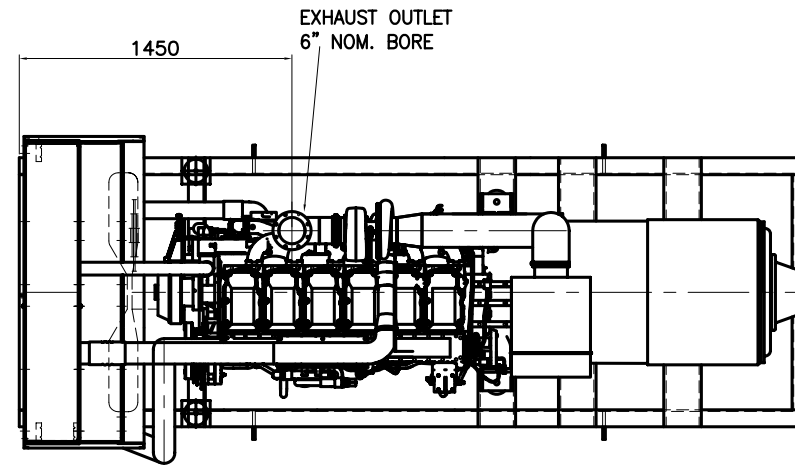

No. ALTERATIONS CHK'D DATE

NOTES - MECHANICAL

TOLERANCES:  
 GENERAL TOLERANCE + / - 5MM  
 FABRICATION + / - 3MM  
 HOLE CENTRES + / - 1MM  
 OTHER TOLERANCES AS STATED  
 WHERE REQUIRED

DO NOT SCALE  
 IF IN DOUBT ASK  
 THIRD ANGLE PROJECTION

NOTES - ELECTRICAL

CABLE SIZE: 1.5MM  
 UNLESS OTHERWISE STATED  
 CABLE COLOURS  
 DC CONTROL: VIOLET  
 DC POWER: POSITIVE BROWN  
 NEGATIVE BLUE  
 AC POWER SINGLE PHASE: LIVE BROWN  
 NEUTRAL BLUE  
 AC POWER THREE PHASE: L1 BROWN  
 L2 BLACK, L3 GREY, NEUTRAL BLUE  
 AC CONTROL: BLACK

TITLE: GENSET GENERAL ARRANGMENT

CLIENT:

SITE:

W.O. No.: ENGINEER: SKM

TYPE: BCC800P/880S DRAWN BY: SKM

SCALE: NTS DATE: 23.11.05

TOTAL No. OF SHEETS (1 - 999) 1

DRAWING NO. ISSUE

BCC800P MASTER A

**BROADCROWN**

THIS IS NOT AN OFFICIAL CONTRACT DRAWING — FOR PRELIMINARY USE ONLY.