



**GeneratorJoe**

4016 Quartz Drive  
 Santa Rosa, CA 95405  
 Phone: 707 539-9003  
 Fax: 707 539-5212  
 Email: sales@generatorjoe.NET  
 Web www.generatorjoe.NET

NOTES  
 FOR GEN SET TYPES BCLP 13 & BCLP 10 SP  
 ENGINE TYPE: LISTER PETER LPW3  
 ALTERNATOR: NEWAGE BCI 164

GENERATOR TO BE PLACED DIRECTLY ONTO A FLAT,  
 LEVEL CONCRETE BASE.  
 (FIX TO BASE USING 4 OFF 12mm DIA HOLES AS  
 DETAILED IN DRAWING)

SHIPPING WEIGHT: 411kg

WET WEIGHT (WITH LUBE OIL, COOLANT AND FUEL):  
 470kg

TOTAL ENGINE OIL CAPACITY: 4 litres

COOLING SYSTEM CAPACITY (50:50 WATER:GLYCOL) :  
 6.5 litres

NOTE, SILENCER IS SHIPPED LOOSE (ALL FITTINGS  
 SUPPLIED)

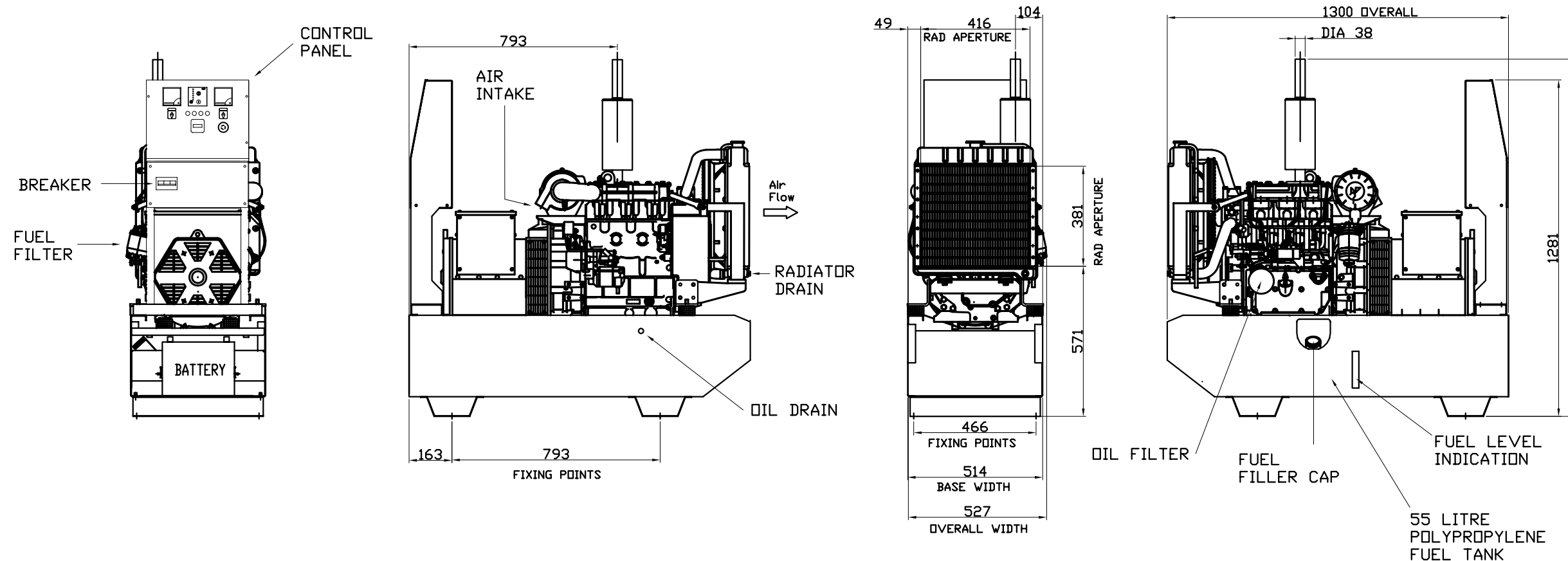

ISS	ALTERATIONS	DATE

NOTES

TOLERANCES:  
 BETWEEN HOLE CENTRES & HOLE  
 CENTRE TO EDGE (ON FLAT) ± 0.2

HOLE CENTRES TO BEND AND  
 EDGES TO BEND ± 0.5

ACROSS EACH BEND ± 0.5

FABRICATION ± 1.0

HOLE DIAMETERS AND SLOT  
 WIDTHS +0.1, -0.0

ANGULAR ± 0.5°

THIRD ANGLE PROJECTION  
 DO NOT SCALE, IF IN DOUBT ASK

DISTRIBUTION		
MASTER	FABRICATOR	
TITLE:	LISTER PETER LPW3 GENSET	
CLIENT:		
SITE:		
W.O. No.:	ENGINEER:	PJA
TYPE:	LISTER PETER	CHECKED:
SCALE:	NTS	DATE:
TOTAL No. OF SHEETS: 1		
DRAWING NO.		ISSUE
LOS001GA		A
<b>BROADCROWN</b>		