

NOTES
 FOR GEN SET TYPES BCD15P/16S & BCD12PSP/13SSP
 ENGINE TYPE: DEUTZ 2009 L03
 ALTERNATOR: NEWAGE BCI 164



GeneratorJoe

4016 Quartz Drive
 Santa Rosa, CA 95405
 Phone: 707 539-9003
 Fax: 707 539-5212
 Email: sales@generatorjoe.NET
 Web www.generatorjoe.NET

GENERATOR TO BE PLACED DIRECTLY ONTO A FLAT,
 LEVEL CONCRETE BASE.
 (FIX TO BASE USING 4 OFF 12mm DIA HOLES AS
 DETAILED IN DRAWING)

SHIPPING WEIGHT: 417kg

WET WEIGHT (WITH LUBE OIL, COOLANT AND FUEL):
 480kg

TOTAL ENGINE OIL CAPACITY: 5.25 litres

COOLING SYSTEM CAPACITY (50:50 WATER:GLYCOL) :
 7.6 litres

NOTE, SILENCER IS SHIPPED LOOSE (ALL FITTINGS
 SUPPLIED)

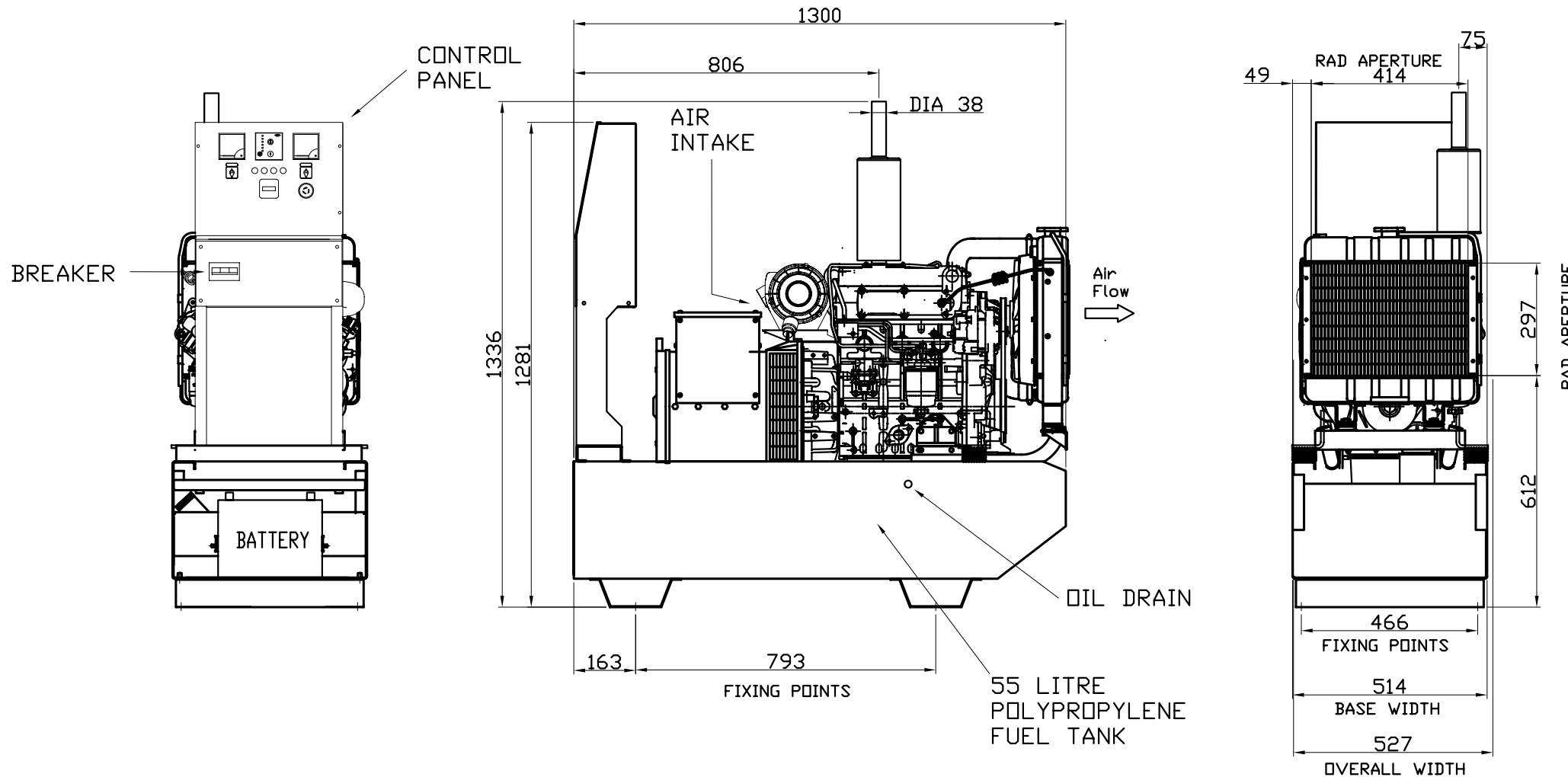

ISS	ALTERATIONS	DATE

NOTES

TOLERANCES:
 BETWEEN HOLE CENTRES & HOLE
 CENTRE TO EDGE (ON FLAT) ± 0.2

HOLE CENTRES TO BEND AND
 EDGES TO BEND ± 0.5

ACROSS EACH BEND ± 0.5

FABRICATION ± 1.0

HOLE DIAMETERS AND SLOT
 WIDTHS +0.1, -0.0

ANGULAR ± 0.5°

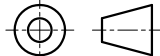

THIRD ANGLE PROJECTION
 DO NOT SCALE, IF IN DOUBT ASK

DISTRIBUTION	
MASTER	FABRICATOR
TITLE:	DEUTZ 2009 L03 GENSET
CLIENT:	
SITE:	
W.O. No.:	ENGINEER: PJA
TYPE:	2009 L03 CHECKED:
SCALE:	NTS DATE:
TOTAL No. OF SHEETS: 1	
DRAWING NO.	ISSUE
DGA005	A
BROADCROWN	