

NOTES
 FOR GEN SET TYPES BCD20P/21S & BCD16PSP/17SSP
 ENGINE TYPE: DEUTZ 2009 L04
 ALTERNATOR: NEWAGE BCI 184

GENERATOR TO BE PLACED DIRECTLY ONTO A FLAT,
 LEVEL CONCRETE BASE.
 (FIX TO BASE USING 4 OFF 12mm DIA HOLES AS
 DETAILED IN DRAWING)

SHIPPING WEIGHT: 481kg

WET WEIGHT (WITH LUBE OIL, COOLANT AND FUEL):
 548kg

TOTAL ENGINE OIL CAPACITY: 7 litres

COOLING SYSTEM CAPACITY (50:50 WATER:GLYCOL) :
 7.7 litres

NOTE, SILENCER MAYBE SHIPPED LOOSE (ALL
 FITTINGS SUPPLIED)



GeneratorJoe

4016 Quartz Drive
 Santa Rosa, CA 95405
 Phone: 707 539-9003
 Fax: 707 539-5212
 Email: sales@generatorjoe.NET
 Web www.generatorjoe.NET

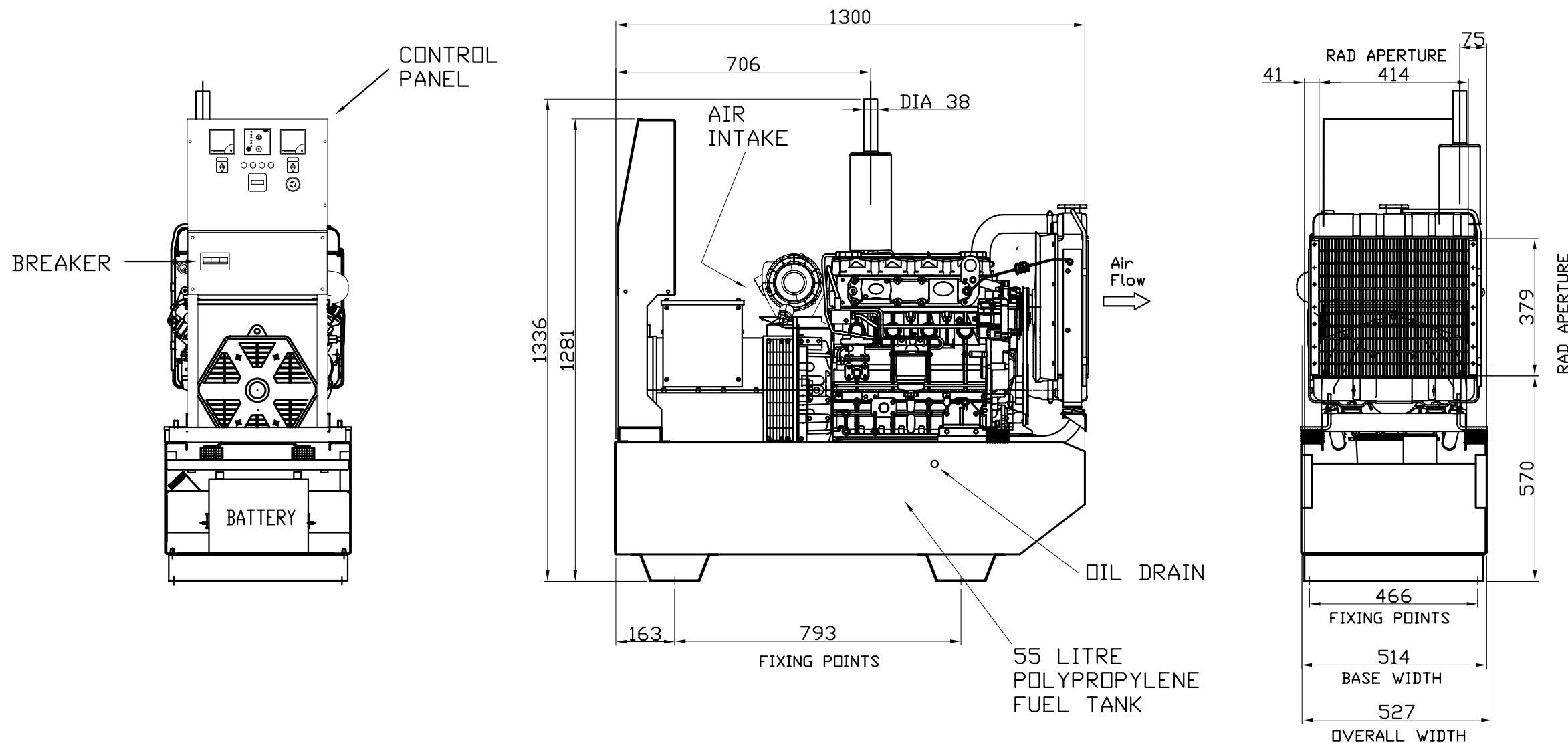

ISS	ALTERATIONS	DATE

NOTES

TOLERANCES:
 BETWEEN HOLE CENTRES & HOLE
 CENTRE TO EDGE (ON FLAT) ± 0.2

HOLE CENTRES TO BEND AND
 EDGES TO BEND ± 0.5

ACROSS EACH BEND ± 0.5

FABRICATION ± 1.0

HOLE DIAMETERS AND SLOT
 WIDTHS +0.1, -0.0

ANGULAR ± 0.5°

THIRD ANGLE PROJECTION
 DO NOT SCALE, IF IN DOUBT ASK

DISTRIBUTION			
MASTER	FABRICATOR		
TITLE:	DEUTZ 2009 L04 GENSET		
CLIENT:			
SITE:			
W.O. No.:	ENGINEER:	PJA	
TYPE:	2009 L04	CHECKED:	
SCALE:	NTS	DATE:	
TOTAL No. OF SHEETS: 1			
DRAWING NO. DGA006			ISSUE A
BROADCROWN			

A
B
C
D
E
F
G
H

1 2 3 4 5 6 7 8