



GeneratorJoe

4016 Quartz Drive
 Santa Rosa, CA 95405
 Phone: 707 539-9003
 Fax: 707 539-5212
 Email: sales@generatorjoe.NET
 Web www.generatorjoe.NET

NOTES:-
 ENGINE: VOLVO TAD941GE
 ALTERNATOR: NEWAGE HCI 434E (SINGLE BEARING)
 RADIATOR: SUPPLIED WITH ENGINE
 A.V. MOUNTS: FARRAT SERIES - 6 OFF
 FUEL TANK CAPACITY 600 Ltrs

GEN-SET DETAILS-
 POWER OUTPUT 325 KVA
 VOLTAGE 400
 FREQUENCY 50Hz

BASEFRAME FUEL TANK - 600 LITRES USABLE.

WEIGHTS:-
 ENGINE: 1015 KG DRY, 1065 KG WET
 ALTERNATOR: 1005 KG
 RADIATOR: 339 KG WET
 BASEFRAME: 550 KG DRY, 1060 KG WET

GENERATOR : 2970 KG DRY, 3530 KG WET

COLOURS:-
 Baseframe, Alternator & Radiator: Semi-Gloss Black
 Engine: Maize Yellow

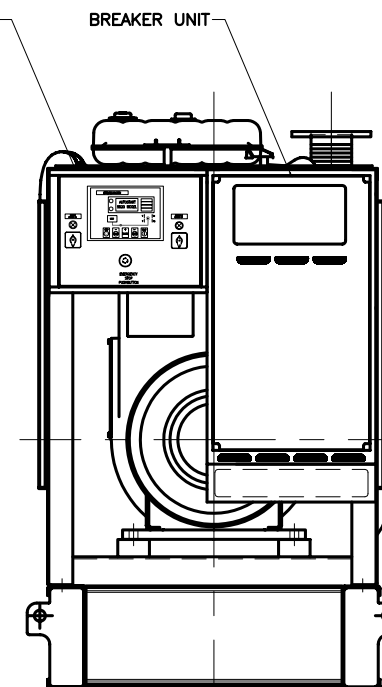
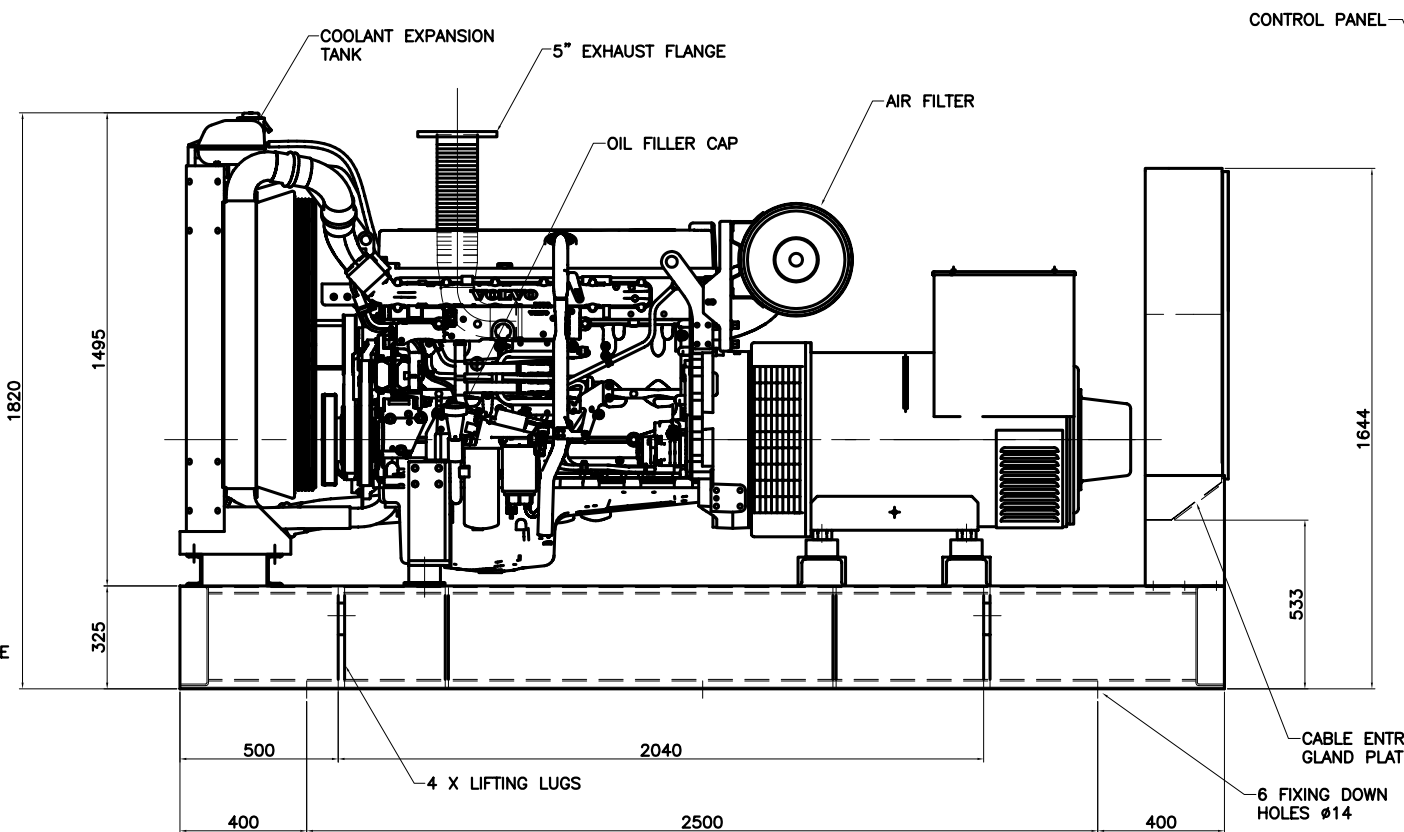
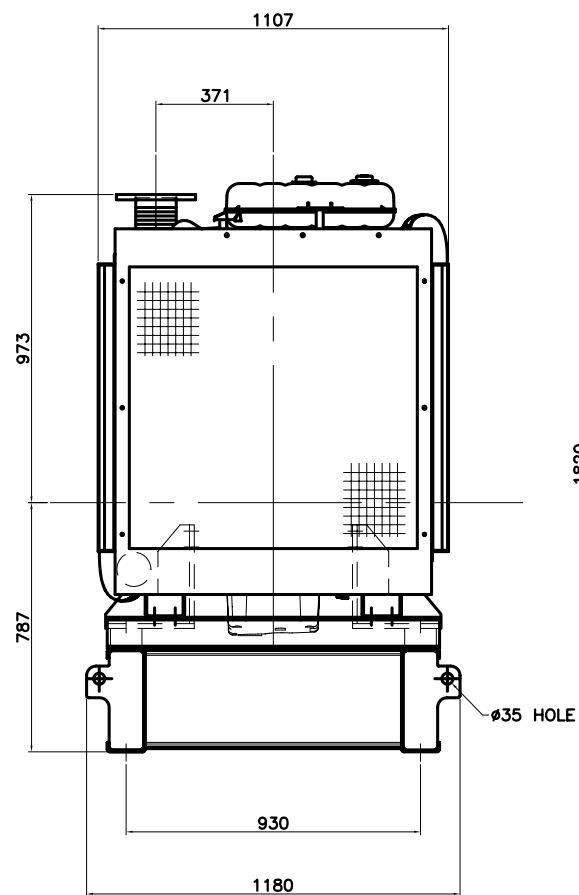
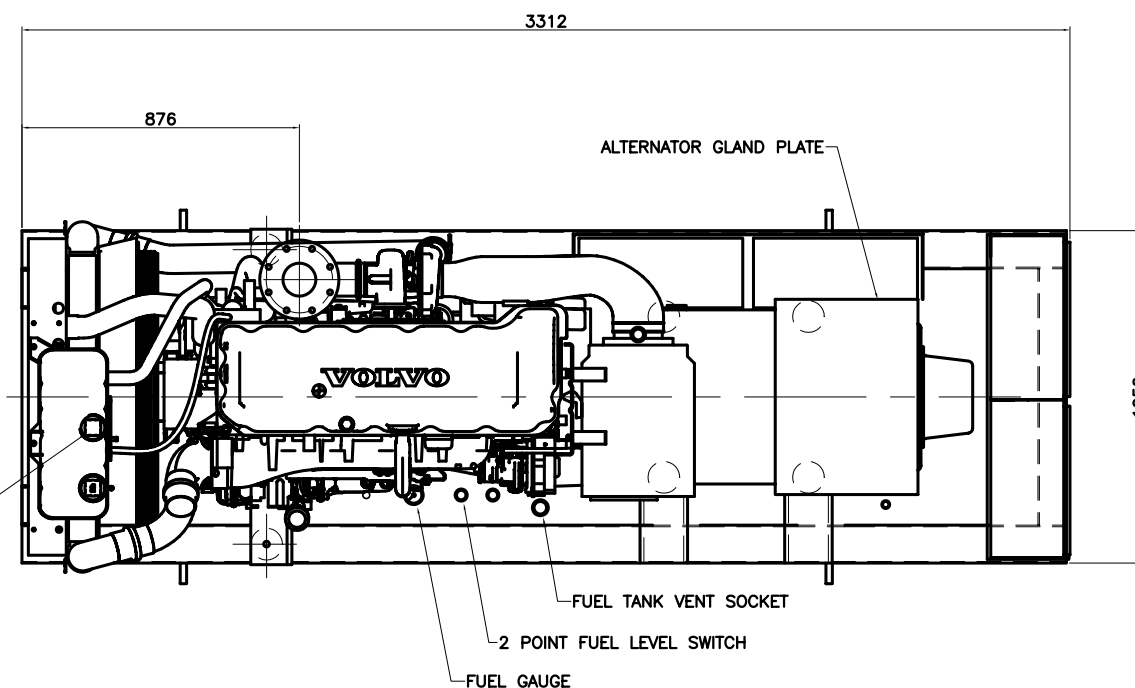

No. ALTERATIONS CHK'D DATE

TOLERANCES:
 GENERAL TOLERANCE + / - 5mm
 FABRICATION + / - 3mm
 HOLE CENTRES + / - 1mm
 OTHER TOLERANCES AS STATED
 WHERE REQUIRED

DO NOT SCALE
 IF IN DOUBT ASK
 THIRD ANGLE PROJECTION

NOTES - ELECTRICAL

CABLE SIZE: 1.5MM
 UNLESS OTHERWISE STATED
 CABLE COLOURS
 DC CONTROL: VIOLET
 DC POWER: POSITIVE BROWN
 NEGATIVE BLUE
 AC POWER SINGLE PHASE: LIVE BROWN
 NEUTRAL BLUE
 AC POWER THREE PHASE: L1 BROWN
 L2 BLACK, L3 GREY, NEUTRAL BLUE
 AC CONTROL: BLACK

TITLE: GENSET GENERAL ARRANGEMENT

CLIENT:

W.D. No.: ENGINEER: SKM

TYPE: BCV300P DRAWN BY: SKM

SCALE: NTS DATE: 30.08.07

TOTAL No. OF SHEETS (1 - 999) 1

DRAWING NO. ISSUE

BCV300P-GA01-AI A

