

Generator set pictured may include optional accessories

STANDBY 20 kW
PRIME 18 kW
60 Hz

Model	Standby kW (kVA)	Prime kW (kVA)
D20-4*	20 (25)	18 (22.5)
D20-4S*	20 (20)	18 (18)

*Tier II EPA Approved, Emissions Certified
Consult factory for more details.

FEATURES

GENERATOR SET

- Complete system designed and built at ISO 9001 certified facilities
- Factory tested to design specifications at full load conditions

ENGINE

- Governor, mechanical
- Electrical system, 12 VDC
- Cartridge type filters
- Battery, rack and cables
- Coolant and lube drains piped to edge of base

GENERATOR

- Insulation system, class H
- Drip proof generator air intake (NEMA 2, IP23)
- Electrical design in accordance with BS5000 Part 99, IEC60034-1, EN61000-6, NEMA MG-1.33

CONTROL SYSTEM

- EMCP3.1 digital control panel
- Vibration isolated NEMA 1 enclosure with lockable hinged door
- DC and AC wiring harnesses

MOUNTING ARRANGEMENT

- Heavy-duty fabricated steel base raised for forklift access
- Seismic (Zone 4) vibration isolators
- Directly mounted 10 dB(A) silencer
- Complete OSHA guarding
- Flexible fuel lines to base with NPT connections

COOLING SYSTEM

- Radiator and cooling fan complete with protective guards
- Standard ambient temperatures up to 50° C (122° F)

CIRCUIT BREAKER

- UL/CSA (mainline) listed
- 3-pole with solid neutral
- NEMA 1 steel enclosure, vibration isolated
- Electrical stub-up area directly below circuit breaker

AUTOMATIC VOLTAGE REGULATOR

- Voltage within $\pm 0.5\%$ 3 Phase and $\pm 1.0\%$ Single Phase at steady state from no load to full load
- Provides fast recovery from transient load changes

EQUIPMENT FINISH

- All electroplated hardware
- Anticorrosive protection prior to painting
- High gloss polyurethane paint for durability and scuff resistance

QUALITY STANDARDS

- BS4999, BS5000, BS5514, EN61000-6, IEC60034, NEMA MG-1.33, NFPA 110 (with optional equipment)

DOCUMENTATION

- Operation and maintenance manuals provided
- Wiring diagrams included

WARRANTY

- All equipment carries full manufacturer's warranty.

4016 Quartz Drive
Santa Rosa, CA 95405
Phone: 707 539-9003
Fax: 707 539-5212

Email: sales@generatorjoe.NET
Web www.generatorjoe.NET

OPTIONAL EQUIPMENT*

ENCLOSURE

- Sound attenuated enclosure (includes internal silencer system)
- Single point lift
- Panel viewing window

SILENCER SYSTEM — OPEN UNIT ONLY

- Level 2 Silencer

ENGINE

- Electronic governor

CIRCUIT BREAKER

- Auxiliary voltfree contacts

GENERATOR

- Anti-condensation heater

COOLING SYSTEM

- Coolant heater

CONTROL SYSTEM

- EMCP 3.2 Digital Control Panel

*Some options may not be available on all models.
Not all options are listed.

FUEL SYSTEM

- Single-walled steel fuel tank
- UL Listed double walled, closed top diked tank, skid mounted, nominal 24 hour low level alarm

MISCELLANEOUS ACCESSORIES

- Additional operator's manual pack
- CSA certification
- French or Spanish language labels

EXTENDED SERVICE COVERAGE

- Extended Service Coverage available for both standby and prime applications.

TESTING

- Factory witness test (restricted to 6 hours — full load, 1.0 pf)



GeneratorJoe

4016 Quartz Drive
Santa Rosa, CA 95405
Phone: 707 539-9003
Fax: 707 539-5212
Email: sales@generatorjoe.NET
Web www.generatorjoe.NET

SPECIFICATIONS



GENERATOR

Voltage Regulation ±0.5% 3 Phase and ±1.0%
Single Phase at steady state
from no load to full load

Frequency ±0.8% for constant load,
no load to full load

Waveform Distortion THD <4%, at no load

Radio Interference Compliance with EN61000-6

Telephone Interference TIF <50, THF <2%

Overspeed Limit 2250 rpm

Insulation Class H

Temperature Rise Within Class H limits

Available Voltages 277/480, 120/240, 120/208

Deration Consult factory for available outputs

Ratings At 30° C (86° F), 152.4 m (500 ft),
60% humidity, 1.0 pf (1-Phase), 0.8 pf (3-Phase)



ENGINE

Manufacturer Caterpillar

Type 4-Cycle

Cylinder Configuration In-line 4

Displacement — L (in³) 2.22 (135)

Bore — mm (in) 84 (3.3)

Stroke — mm (in) 100.0 (3.9)

Compression Ratio 23.3:1

Governor Type Mechanical

Class A1

Piston Speed — m/sec (ft/sec) 6 (19.7)

Engine speed — rpm 1800

Air Cleaner Type Dry, replaceable paper
element type with restriction indicator

Regenerative Power — kW 8.64

D20-4 — C2.2

Maximum Power at Rated rpm — kW (hp)

Standby 24.3 (33.0)

Prime 22.0 (29.5)

BMEP — kPa (psi)

Standby 731 (106)

Prime 658 (95.5)

Aspiration Naturally Aspirated

D20-4S — C2.2

Maximum Power at Rated rpm — kW (hp)

Standby 24.3 (33.0)

Prime 22 (29.5)

BMEP — kPa (psi)

Standby 731 (106)

Prime 658 (95.5)

Aspiration Naturally Aspirated



CONTROL PANEL

- Heavy duty sheet steel enclosure with lockable hinged door
- Vibration isolated from generating set
- LCD display
- AC metering
- DC metering
- Fail to Start shutdown
- Low Oil Pressure shutdown
- High Engine Temperature
- Low/High battery voltage
- Underspeed/Overspeed
- Loss of Engine speed detection
- 2 spare fault channels
- 20 event fault log
- 2 LED status indicators
- Lockdown emergency stop push button

RATING DEFINITIONS

Standby — Applicable for supplying continuous electrical power (at variable load) in the event of a utility power failure. No overload is permitted on these ratings. The generator is peak rated (as defined in ISO8528-3).

Prime — Applicable for supplying continuous electrical power (at variable load) in lieu of commercially purchased power. There is no limitation to the annual hours of operation and the generator set can supply 10 percent overload power for 1 hour in 12 hours.



GeneratorJoe

4016 Quartz Drive
Santa Rosa, CA 95405
Phone: 707 539-9003
Fax: 707 539-5212
Email: sales@generatorjoe.NET
Web www.generatorjoe.NET

D20-4 (3-Phase)

Generator Set Technical Data — 1800 rpm/60 Hz			Standby		Prime	
Power Rating*	kW	kVA	20	25	18	22.5
Lubricating System						
Type: Full Pressure						
Oil Filter: Spin-On, Full Flow						
Oil Cooler: Watercooled						
Oil Type Required: API CF-4						
Total Oil Capacity						
Oil Pan						
	L	U.S. gal	10.6	2.8	10.6	2.8
	L	U.S. gal	8.9	2.35	8.9	2.35
Fuel System						
Generator Set Fuel Consumption						
100% Load	L/hr	G/hr	7.0	1.9	6.2	1.6
75% Load	L/hr	G/hr	5.0	1.3	4.5	1.2
50% Load	L/hr	G/hr	3.6	1.0	5.4	0.9
Engine Electrical System						
Voltage/Ground: 12/Negative						
Battery Charging Generator Ampere Rating						
	Amps		55		55	
Cooling System						
Water Pump Type: Centrifugal						
Radiator System Capacity Incl. Engine						
Maximum Coolant Static Head	L	U.S. gal	7	1.8	7	1.8
Coolant Flow Rate	m H ₂ O	ft H ₂ O	3.1	10.2	3.1	10.2
Minimum Temperature to Engine	L/hr	U.S. gal/hr	2910	769	2910	769
Temperature Rise Across Engine	°C	°F	76	169	76	169
Heat Rejected to Coolant at Rated Power	°C	°F	7.4	13.3	7.4	13.3
Total Heat Radiated to Room at Rated Power	kW	Btu/min	22.2	1263	19.9	1132
Radiator Fan Load	kW	Btu/min	8.1	461	7.3	415
	kW	hp	0.4	0.5	0.4	0.5
Air Requirements						
Combustion Air Flow	m ³ /min	cfm	1.74	61.4	1.74	61.4
Maximum Air Cleaner Restriction	kPa	in H ₂ O	6.4	25.6	6.4	25.6
Radiator Cooling Air (zero restriction)	m ³ /min	cfm	46.8	1652	46.8	1652
Generator Cooling Air	m ³ /min	cfm	10.8	382	10.8	382
Allowable Air Flow Restriction (after radiator)	kPa	in H ₂ O	0.125	0.50	0.125	0.50
Cooling Airflow (@ rated speed)						
Rate with restriction	m ³ /min	cfm	39.0	1377	39.0	1377
Exhaust System						
Maximum Allowable Backpressure	kPa	in Hg	3.01	10.2	10.2	3.01
Exhaust Flow at Rated kW	m ³ /min	cfm	168	4.76	4.34	153
Exhaust Temperature at Rated kW — Dry Exhaust	°C	°F	510	950	440	824
Generator Set Noise Rating**						
(Without Attenuation) at 1 m (3 ft)						
	dB(A)		85.7		91.4	

*Three phase power rating

**dBA levels are for guidance only

Generator Technical Data		277/480V		120/208V	
Motor Starting Capability: (kVA) (30% Voltage Dip)		62		39	
Full Load Efficiencies:	Standby	87.1		85.9	
	Prime	87.6		86.6	
Reactances (per unit):	X _d	1.95		2.60	
	X' _d	0.12		0.16	
	X'' _d	0.060		0.080	
	X _q	0.98		1.30	
	X'' _q	0.083		0.111	
	X ₂	0.072		0.095	
	X ₀	0.005		0.007	
Time Constants:		t' _d 25 ms	t'' _d 2.5 ms	t' _{d0} 409 ms	t _a 4 ms



GeneratorJoe

4016 Quartz Drive
Santa Rosa, CA 95405
Phone: 707 539-9003
Fax: 707 539-5212
Email: sales@generatorjoe.NET
Web www.generatorjoe.NET

D20-4S (1-Phase)

Generator Set Technical Data — 1800 rpm/60 Hz			Standby		Prime	
Power Rating*	kW	kVA	20	20	18	18
Lubricating System						
Type: Full Pressure						
Oil Filter: Spin-On, Full Flow						
Oil Cooler: Watercooled						
Oil Type Required: API CF-4						
Total Oil Capacity	L	U.S. gal	10.6	2.8	10.6	2.8
Oil Pan	L	U.S. gal	8.9	2.35	8.9	2.35
Fuel System						
Generator Set Fuel Consumption						
100% Load	L/hr	G/hr	27.07	7.15	24.86	6.57
75% Load	L/hr	G/hr	21.18	5.60	18.69	4.98
50% Load	L/hr	G/hr	15.42	4.07	13.67	3.61
Engine Electrical System						
Voltage/Ground: 12/Negative						
Battery Charging Generator Ampere Rating						
			Amps		55	
Cooling System						
Water Pump Type: Centrifugal						
Radiator System Capacity Incl. Engine						
	L	U.S. gal	7	1.8	7	1.8
Maximum Coolant Static Head	m H ₂ O	ft H ₂ O	3.1	10.2	3.1	10.2
Coolant Flow Rate	L/hr	U.S. gal/hr	2910	769	2910	769
Minimum Temperature to Engine	°C	°F	76	169	76	169
Temperature Rise Across Engine	°C	°F	7.4	13.3	7.4	13.3
Heat Rejected to Coolant at Rated Power	kW	Btu/min	22.2	1263	19.9	1132
Total Heat Radiated to Room at Rated Power	kW	Btu/min	8.1	461	7.3	415
Radiator Fan Load	kW	hp	0.4	0.5	0.4	0.5
Air Requirements						
Combustion Air Flow	m ³ /min	cfm	1.74	61.4	1.74	61.4
Maximum Air Cleaner Restriction	kPa	in H ₂ O	6.4	25.6	6.4	25.6
Radiator Cooling Air (zero restriction)	m ³ /min	cfm	46.8	1652	46.8	1652
Generator Cooling Air	m ³ /min	cfm	26.4	933	26.4	933
Allowable Air Flow Restriction (after radiator)	kPa	in H ₂ O	0.125	0.50	0.125	0.50
Cooling Airflow (@ rated speed)						
Rate with restriction	m ³ /min	cfm	39.0	1377	39.0	1377
Exhaust System						
Maximum Allowable Backpressure						
Exhaust Flow at Rated kW	kPa	in Hg	10.2	3.01	10.2	3.01
Exhaust Temperature at Rated kW — Dry Exhaust	m ³ /min	cfm	4.76	168	4.34	153
	°C	°F	510	950	440	824
Generator Set Noise Rating**						
(Without Attenuation) at 1 m (3 ft)						
			dB(A)		85.7	
					91.4	

*Three phase power rating

**dBA levels are for guidance only

Generator Technical Data		240/120V			
Motor Starting Capability: (30% Voltage Dip)	(kVA)	29			
Full Load Efficiencies:	Standby	85.6			
	Prime	85.6			
Reactances (per unit): Reactances shown are applicable to the standby rating	X _d	1.67			
	X' _d	0.29			
	X ^u _d	0.138			
	X _q	0.83			
	X ^u _q	0.196			
Time Constants:	t' _d	t'' _d	t' _{do}	t _a	
	40 ms	6 ms	360 ms	8 ms	



GeneratorJoe

GENERATOR SET DIMENSIONS AND WEIGHTS

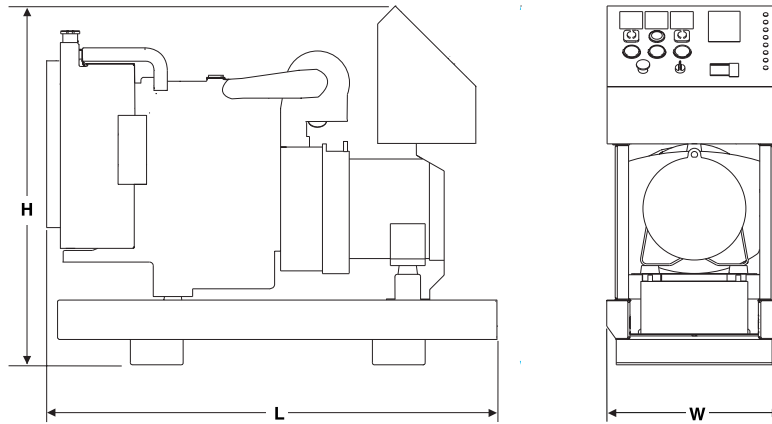

Model	Length mm (in)	Width mm (in)	Height mm (in)	Weight kg (lb)**
D20-4	1425 (56.1)	552 (21.7)	1134 (44.6)	450 (992)
D20-4S	1425 (56.1)	552 (21.7)	1134 (44.6)	450 (992)

Note: General configuration not to be used for installation. See specific dimensional drawings for detail.

**Includes oil and coolant



GeneratorJoe

4016 Quartz Drive
 Santa Rosa, CA 95405
 Phone: 707 539-9003
 Fax: 707 539-5212
 Email: sales@generatorjoe.NET
 Web www.generatorjoe.NET

**STANDBY
PRIME
60 Hz**

**20 kW
18 kW**

CATERPILLAR®

This page intentionally left blank.



GeneratorJoe

4016 Quartz Drive
Santa Rosa, CA 95405
Phone: 707 539-9003
Fax: 707 539-5212
Email: sales@generatorjoe.NET
Web www.generatorjoe.NET

STANDBY
PRIME
60 Hz

20 kW
18 kW

CATERPILLAR®

This page intentionally left blank.



GeneratorJoe

4016 Quartz Drive
Santa Rosa, CA 95405
Phone: 707 539-9003
Fax: 707 539-5212
Email: sales@generatorjoe.NET
Web www.generatorjoe.NET

Market: N. America

LEHE4997-01 (06-05)

Information contained in this publication may be considered confidential
Discretion is recommended when distributing.

Materials and specifications are subject to change without notice.

CAT, CATERPILLAR, their respective logos and "Caterpillar Yellow," as well as corporate and product
identity used herein, are trademarks of Caterpillar and may not be used without permission.

© 2005 Caterpillar
All Rights Reserved.
Printed in U.S.A.