

Exclusively from your Caterpillar® dealer



## GeneratorJoe

**STANDBY 200 kW**  
**PRIME 180 kW**  
60 Hz

Model	Standby kW (kVA)	Prime kW (kVA)
D200P3	200 (250)	180 (225)



4016 Quartz Drive  
Santa Rosa, CA 95405  
Phone: 707 539-9003  
Fax: 707 539-5212  
Email: sales@generatorjoe.NET  
Web www.generatorjoe.NET

## FEATURES

### GENERATOR SET

- Complete system designed and built at ISO 9001 certified facilities
- Factory tested to design specifications at full load conditions

### ENGINE

- Governing, electronic
- Electrical system, 24 VDC
- Cartridge type filters
- Battery(ies), rack and cables
- Coolant and lube drains piped to edge of base

### GENERATOR

- Insulation system, class H
- Electrical design in accordance with BS5000 Part 99, IEC60034-1, EN61000-6, NEMA MG-1.33

### CONTROL SYSTEM

- 2001 Series Autostart control panel
- Vibration isolated NEMA 1 enclosure with lockable hinged door
- DC and AC wiring harnesses

### MOUNTING ARRANGEMENT

- Heavy-duty fabricated steel base with lifting points
- Anti-vibration pads to ensure vibration isolation
- Complete OSHA guarding
- Stub-up pipe ready for connection to silencer pipework
- Flexible fuel lines to base with NPT connections

### COOLING SYSTEM

- Radiator and cooling fan complete with protective guards
- Standard ambient temperatures up to 122° F (50° C)

### CIRCUIT BREAKER

- UL/CSA listed
- 3-pole with solid neutral
- NEMA 1 steel enclosure, vibration isolated
- Electrical stub-up area directly below circuit breaker

### AUTOMATIC VOLTAGE REGULATOR

- Voltage within ± 0.5% at steady state from no load to full load
- Provides fast recovery from transient load changes

### EQUIPMENT FINISH

- All electroplated hardware
- Anticorrosive paint protection
- High gloss polyurethane paint for durability and scuff resistance

### QUALITY STANDARDS

- BS4999, BS5000, BS5514, IEC60034, EN61000-6, NEMA MG-1.33, NFPA 110 (with optional equipment)

### DOCUMENTATION

- Operation and maintenance manuals provided
- Wiring diagrams included

### WARRANTY

- All equipment carries full manufacturer's warranty.

**STANDBY 200 kW**  
**PRIME 180 kW**  
**60 Hz**

**OLYMPIAN™**

**OPTIONAL EQUIPMENT\***

**ENCLOSURE**

- B Series weather protective enclosure (includes internal silencer system)
  - Single point lift
  - Panel viewing window
  - External emergency stop pushbutton
- Sound attenuated enclosure (includes internal silencer system)

**SILENCER SYSTEM — OPEN UNIT**

- Level 1 silencer 10 dBA
- Level 2 silencer 25 dBA
- Level 3 silencer 35 dBA
- Mounting kits
- Through-wall installation kits

**ENGINE**

- Battery heater
- Lube oil drain pump
- High lube oil temperature shutdown
- Lube oil sump heater

**CIRCUIT BREAKER**

- Auxiliary voltfree contacts
- Shunt trip (100+ amp breakers)

**GENERATOR**

- Anti-condensation heater
- Permanent magnet generator
- AREP excitation system
- Generator upgrade 1 size

**CONTROL SYSTEM**

- No control system
- 4001 Autostart control panel
- 4001E Autostart control panel

**MOUNTING ACCESSORIES**

- Seismic (Zone 4) vibration isolators

**FUEL SYSTEM**

- Single-walled metal fuel tank
- UL listed closed top-diked skid-mounted fuel tank base (12/24-hour capacity) with fuel alarm (low level/leak detected)
- Critical high fuel alarm
- Low fuel alarm

**COOLING SYSTEM**

- Coolant heater
- Low coolant temperature alarm
- Low coolant level shutdown
- Radiator transition flange

**REMOTE ANNUNCIATORS**

- 8- and 16-channel remote annunciator panel (supplied loose)
- Remote annunciator upgrade normal/run control switch
- Remote annunciator upgrade lockdown emergency stop button

**MISCELLANEOUS ACCESSORIES**

- Toolkit
- Additional operator’s manual pack
- Special enclosure color
- UL certification
- CSA certification
- French or Spanish language labels

**EXTENDED SERVICE CONTRACTS**

- Extended Service Coverage available

**TESTING**

- Factory witness test (restricted to 6 hours — full load, 1.0 pf)

**GeneratorJoe**

\*Some options may not be available on all models. Not all options are listed.

**GENERATOR SET DIMENSIONS AND WEIGHTS**

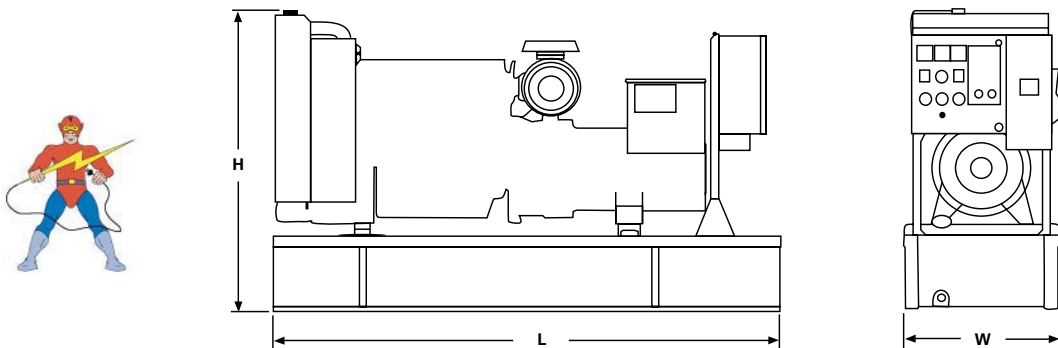

4016 Quartz Drive  
 Santa Rosa, CA 95405  
 Phone: 707 539-9003  
 Fax: 707 539-5212  
 Email: sales@generatorjoe.NET  
 Web www.generatorjoe.NET

**NOTE:** General configuration not to be used for installation. See specific dimensional drawings for detail.

\*\*Includes oil and coolant

Model	Length in (mm)	Width in (mm)	Height in (mm)	Weight lbs (kg)**
D200P3	117 (2972)	39.5 (1003)	67.6 (1718)	4513 (2047)

**STANDBY 200 kW**  
**PRIME 180 kW**  
**60 Hz**

**OLYMPIAN™**

**SPECIFICATIONS**



**GENERATOR**

Voltage Regulation ..... ±0.5% at steady state from no load to full load  
 Frequency ..... ±0.25% for constant load, no load to full load  
 Waveform Distortion ..... THD < 4%, at no load  
 Radio Interference ..... Compliance with EN61000-6  
 Telephone Interference ..... TIF <50, THF <2%  
 Overspeed Limit ..... 2250 rpm  
 Insulation ..... Class H  
 Temperature Rise ..... Within Class H limits  
 Available Voltages ..... 277/480, 266/460, 120/240, 127/220, 120/208, 347/600  
 Deration ..... Consult factory for available outputs  
 Ratings ..... At 86° F (30° C), 500 ft. (152.4 m), 60% humidity, 0.8 pf



**ENGINE**

Manufacturer ..... Perkins  
 Type ..... 4-Cycle  
 Cylinder Configuration ..... In-line 6  
 Displacement — cu in (L) ..... 531 (8.7)  
 Bore — in (mm) ..... 4.59 (116.6)  
 Stroke — in (mm) ..... 5.35 (135.9)  
 Governor  
   Type ..... Electronic  
   Class ..... A1  
 Piston Speed — ft/sec (m/sec) ..... 26.9 (8.2)  
 Engine speed — rpm ..... 1800  
 Air Cleaner Type ..... Dry, replaceable paper element type with restriction indicator

**D200P3 — 1306E87TA300**

Compression Ratio ..... 16.9:1  
 Max Power at Rated rpm — hp (kW)  
   Standby ..... 325 (242)  
   Prime ..... 295 (220)  
 BMEP — psi (kPa)  
   Standby ..... 269 (1855)  
   Prime ..... 245 (1686)  
 Regenerative Power — kW ..... 28.6  
 Aspiration ..... Turbocharged, AA Charge Cooled



**CONTROL PANEL**

NEMA 1 steel enclosure with lockable hinged door  
 Vibration isolated mounted Autostart control panel  
 Single location customer connector point  
 Electrical stub-up area directly below control panel

**RATING DEFINITIONS**

**Standby** — Applicable for supplying continuous electrical power (at variable load) in the event of a utility power failure. No overload is permitted on these ratings. The generator is peak rated (as defined in ISO8528-3).

**Prime** — Applicable for supplying continuous electrical power (at variable load) in lieu of commercially purchased power. There is no limitation to the annual hours of operation and the generator set can supply 10 percent overload power for 1 hour in 12 hours.



**GeneratorJoe**

4016 Quartz Drive  
 Santa Rosa, CA 95405  
 Phone: 707 539-9003  
 Fax: 707 539-5212  
 Email: sales@generatorjoe.NET  
 Web www.generatorjoe.NET

© 2004 Caterpillar  
 All rights reserved.  
 Printed in U.S.A.

**STANDBY 200 kW**  
**PRIME 180 kW**  
**60 Hz**



**OLYMPIAN™**

**D200P3 (3-phase)**

Materials and specifications are subject to change without notice.

<b>Generator Set Technical Data — 1800 rpm/60 Hz</b>		<b>Standby</b>	<b>Prime</b>
<b>Power Rating</b>	kW (kVA)	200 (250)	180 (225)
<b>Lubricating System</b> Type: Full Pressure Oil Filter: Spin-On, Full Flow Oil Cooler: Watercooled Oil Type Required: API CF-4 Total Oil Capacity Oil Pan	U.S. gal (L) U.S. gal (L)	7.5 (28.3) 6.0 (22.7)	7.5 (28.3) 6.0 (22.7)
<b>Fuel System</b> Generator Set Fuel Consumption 100% Load 75% Load 50% Load	g/hr (L/hr) g/hr (L/hr) g/hr (L/hr)	16.18 (61.26) 12.3 (46.4) 8.9 (33.6)	14.66 (55.5) 11.1 (41.2) 8.06 (30.5)
<b>Engine Electrical System</b> Voltage/Ground: 24/Negative Battery Charging Generator Ampere Rating	amps	45	45
<b>Cooling System</b> Water Pump Type: Centrifugal Radiator System Capacity Incl. Engine Maximum Coolant Static Head Coolant Flow Rate Minimum Temperature to Engine Temperature Rise Across Engine Heat Rejected to Coolant at Rated Power Total Heat Radiated to Room at Rated Power Radiator Fan Load	U.S. gal (L) ft H <sub>2</sub> O (m H <sub>2</sub> O) U.S. gal/hr (L/hr) °F (°C) °F (°C) Btu/min (kW) Btu/min (kW) hp (kW)	9.8 (37.2) 51.0 (15.5) 5559.8 (21 060) 174 (79) 9 (5.0) 6216 (110) 2561 (45) 15.0 (11.2)	9.8 (37.2) 51.0 (15.5) 5559.8 (21 060) 174 (79) 9 (5.0) N/A N/A 15.0 (11.2)
<b>Air Requirements</b> Combustion Air Flow Maximum Air Cleaner Restriction Radiator Cooling Air (zero restriction) Generator Cooling Air Allowable Air Flow Restriction (After radiator) Cooling Airflow (@ rated speed) Rate with restriction	cfm (m <sup>3</sup> /min) in H <sub>2</sub> O (kPa) cfm (m <sup>3</sup> /min) cfm (m <sup>3</sup> /min) in H <sub>2</sub> O (kPa) cfm (m <sup>3</sup> /min)	713 (20.2) 25 (6.2) 18,220 (516) 1081 (30.6) 0.50 (0.125) 14,620 (414)	N/A N/A 18,220 (516) 1081 (30.6) 0.50 (0.125) 14,620 (414)
<b>Exhaust System</b> Maximum Allowable Backpressure Exhaust Flow at Rated kW Exhaust Temperature at Rated kW — Dry Exhaust	in Hg (kPa) cfm (m <sup>3</sup> /min) °F (°C)	3.2 (10.7) 1811 (51.3) 891 (477)	3.2 (10.7) N/A N/A
<b>Generator Set Noise Rating*</b> (Without Attenuation) at 3 ft (1 m)	dB(A)	97	97

<b>Generator Technical Data</b>	<b>277/480V</b>	<b>266/460V</b>	<b>127/220V</b>	<b>120/240V 120/208V</b>	<b>347/600V</b>
<b>Motor Starting Capability:</b> (kVA) (30% Voltage Dip)					
Self Excited	454	422	392	355	N/A
PM Excited	543	506	469	425	543
AREP Excited	543	506	469	425	543
<b>Full Load Efficiencies:</b>					
Standby	92.7	92.7	92.6	92.2	92.7
Prime	92.9	93.0	92.8	92.5	92.9
<b>Reactances (per unit):</b>					
X <sub>d</sub>	3.13	3.41	3.73	4.17	3.13
X' <sub>d</sub>	0.15	0.17	0.18	0.20	0.15
X'' <sub>d</sub>	0.092	0.101	0.110	0.123	0.092
X <sub>q</sub>	1.88	2.05	2.24	2.50	1.88
X'' <sub>q</sub>	0.114	0.124	0.136	0.152	0.114
X <sub>2</sub>	0.103	0.112	0.122	0.137	0.103
X <sub>0</sub>	0.005	0.006	0.006	0.007	0.005
<b>Time Constants:</b>	t' <sub>d</sub> 100 ms	t'' <sub>d</sub> 10 ms	t' <sub>do</sub> 2042 ms	t <sub>a</sub> 15 ms	

\* dB(A) levels are for guidance only

**GeneratorJoe**