



DETROIT DIESEL



S SERIES DIESEL

400-XS6DT3

400 ekW 60 Hz Standby

208 - 600V

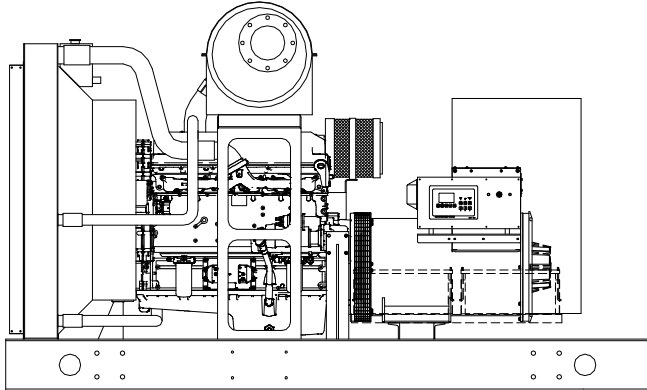

- EPA Tier 3 Certified
- Generator Set Tested to ISO 8528-5 for Transient Response
- UL2200, CSA Listing Offered
- Accepts Rated Load in One Step Per NFPA 110, Level 1
- All gen-sets are prototype and factory tested
- MTU DD is a single source supplier
- Global Product Support
- 2 Year Standard Warranty
- Complete Range of Accessories

- Series 60 (6063HV35) Diesel Engine
 - 14.0 Liter Displacement
 - Electronic Unit Pump Injection
 - 4-Cycle
- Permanent Magnet Generator (PMG) - optional
 - Brushless, Rotating Field
 - 300% Short Circuit Capability
 - 2/3 Pitch Windings
- Digital Control Panel(s)
 - UL Recognized, **UL** **us**, NFPA 110
 - Complete System Metering
 - LCD Display
- Cooling System
 - Integral Set-mounted
 - Engine Driven Fan

GEN-SET RATINGS

Standby

Voltage (L-L)	Phase	PF	Hz	kW	kVA	AMPS	skVA @ 30% voltage dip	Generator Model*	Temp Rise	Connection
208v**	3	0.8	60	400	500	1388	820	433PSL6220	130°C/27°C	12 LEAD HI DELTA
240v**	3	0.8	60	400	500	1203	820	433PSL6220	130°C/27°C	12 LEAD HI WYE
480v**	3	0.8	60	400	500	601	1100	433PSL6220	130°C/27°C	4 LEAD WYE
600v**	3	0.8	60	400	500	481	1100	433PSL6248	125°C/40°C	6 LEAD WYE



GeneratorJoe

4016 Quartz Drive
 Santa Rosa, CA 95405
 Phone: 707 539-9003
 Fax: 707 539-5212
 Email: sales@generatorjoe.NET
 Web www.generatorjoe.NET

* The Generator Model Number identified in the table is for standard C Series Configuration. Consult the factory for alternate configuration.

** UL2200 Offered



STANDARD EQUIPMENT

ENGINE

- Air Cleaner
- Oil Pump
- Full Flow Oil Filter
- Jacket Water Pump
- Closed Crankcase Vent
- Thermostats
- Exhaust Manifold – dry
- Blower Fan & Fan Drive
- Radiator - Unit Mounted
- Electric Starting Motor - 24V
- Governor – Electric Isochronous
- Base - Formed Steel
- SAE Flywheel & Bell Housing
- Charging Alternator - 24V
- Battery Box & Cables
- Flexible Fuel Connectors
- Flexible Exhaust Connection
- EPA Certified Engine

DIGITAL CONTROL PANEL(S)

- Digital Metering
- Engine Parameters
- Generator Protection Functions
- Engine Protection
- SAE J1939 Engine ECU Communications
- Windows-based Software
- Multilingual Capability
- Remote Communications to our RDP-110 Remote Annunciator
- 16 Programmable Contact Inputs
- 7 Contact Outputs
- UL Recognized, cULus, CE Approved
- Event Recording
- IP 54 Front Panel Rating with Integrated Gasket
- NFPA110 Level Compatible

GENERATOR

- NEMA MG1, IEEE and ANSI standards compliance for temperature rise and motor starting
- Sustained short circuit current of up to 300% of the rated current for up to 10 seconds
- Self Ventilated and Drip-proof
- Superior Voltage Waveform
- Digital, Solid State, Volts-per-hertz Regulator
- No load to full load regulation
- Brushless Alternator with Brushless Pilot Exciter
- 4 pole, Rotating Field
- 130°C Standby Temperature Rise
- 1 Bearing, Sealed
- Flexible Coupling
- Full Amortisseur Windings
- 125% Rotor Balancing
- 3-phase Voltage Sensing
- ±.25% Voltage Regulation
- 100% of Rated Load - One Step
- 3% Maximum Harmonic Content

ADDITIONAL FEATURES

- Oil Drain Extension & S/O Valve
- Flexible Fuel Connector
- Battery Cables
- Vibration Isolation Pads
- Jacket Water Heater: -20° F
- Mainline Circuit Breaker
- UL2200 Listed
- Steel Sub-base
- Radiator Duct Flange (OPU)
- Lube Oil & Antifreeze
- Operator's and Owner's Manual
- 2 year/3000 hour Warranty
- Factory Tested at .8 PF (3 PH)

OPTIONAL FEATURES

- Battery Charger 6 amp or 10 amp
- Battery: 24 volt w/ rack
- Circuit Breaker: Standard or 100%
- Muffler (OPU only)
- Sub-base Fuel Tank w/ Electrical stub-up area
- Weatherproof Enclosure
- Sound Attenuation
 - 1 1/2" Foam
 - Sound Scoops
- Remote Annunciator
- Isochronous Governor



GeneratorJoe

4016 Quartz Drive
 Santa Rosa, CA 95405
 Phone: 707 539-9003
 Fax: 707 539-5212
 Email: sales@generatorjoe.NET
 Web www.generatorjoe.NET



APPLICATION DATA

Engine

Manufacturer: MTU Detroit Diesel	Rated RPM: 1800
Model: Series 60 (6063HV35)	Engine Governor: DDEC
Type: 4-Cycle	Max Power: Standby: bhp (kWm) 635 (473)
Arrangement: 6-Inline	Speed Regulation: ±.25%
Displacement: in. ³ (lit) 855 (14.0)	Frequency: 60 Hz
Bore: in. (cm) 5.24 (13.3)	Air Cleaner: Dry
Stoke: in. (cm) 6.61 (16.8)	
Compression Ratio: 16.0:1	

Liquid Capacity (Lubrication)

Total oil system: gal (lit) 9.5 (36)
Engine jacket water capacity: gal (lit) 6.0 (23)
System Coolant capacity: gal (lit) 42 (159)

Electrical

Electric volts DC 24
Cold cranking Amps under 0°F (-17.8°C) 950

Fuel System

Fuel Supply Connection Size: 1/2" NPT
Fuel Return Connection Size: 1/2" NPT
Maximum Fuel Lift: ft (m) 6.7 (2.1)
Recommended Fuel: Diesel #2
Total Fuel Flow: gal/hr (lit/hr) 88.3 (334)

Fuel Consumption

	Standby
At 100% of Power Rating: gal/hr (lit/hr)	31.9 (121)
At 75% of Power Rating: gal/hr (lit/hr)	24.7 (93)
At 50% of Power Rating: gal/hr (lit/hr)	16.7 (63)

Cooling - Radiator System

	Standby
Ambient Capacity of Radiator: °F (°C)	122 (50)
Maximum Allowable Static Pressure on Rad. Exhaust: in. H ₂ O (kPa):	0.5 (.12)
Water Pump Capacity: gal/min (lit/min)	96 (363)
Heat Rejection to Coolant BTUM (kW):	8,750 (154)
Heat Rejection to Air to Air BTUM (kW):	6,250 (110)
Heat Radiated to Ambient: BTUM (kW):	5,671 (100)

Air Requirements

	Standby
Aspirating: CFM (m ³ min)	1,290 (37)
Air Flow Required for Radiator Cooled Unit: CFM (m ³ min)	26,893 (762)
Air Flow Required for Heat Exchanger/ Remote Radiator based on 25°F Rise: CFM (m ³ min)	15,753 (446)



4016 Quartz Drive
 Santa Rosa, CA 95405
 Phone: 707 539-9003
 Fax: 707 539-5212
 Email: sales@generatorjoe.NET
 Web www.generatorjoe.NET

Exhaust System

	Standby
Gas Temp. (Stack) °F (°C):	1,025 (552)
Gas Volume at Stack Temp CFM (m ³ min):	3,594 (101.8)
Maximum Allowable Back Pressure H ₂ O (kPa):	40.8 (10.2)



EMISSIONS DATA

NOx + NMHC	CO	PM
2.66	0.98	0.13

All units are in g/hp-hr and are EPA D2 cycle values.

Emission levels of the engine may vary as a function of ambient temperature, barometric pressure, humidity, fuel type and quality, installation parameters, measuring instrumentation, etc. The data provided are laboratory results from one engine representing this rating. The data was obtained under controlled environmental conditions with calibrated instrumentation traceable to the United States National Bureau of Standards and in compliance with US EPA regulations found within 40 CFR Part 89. The weighted cycle value from each engine is guaranteed to be below the US EPA Standards at the US EPA defined conditions.

SOUND DATA

	Standby Full Load	Standby No Load
23 ft (7m) OPU w/ critical grade muffler (dBA)	96.5	89
23 ft (7m) Sound Attenuated Enclosure (dBA)	88.5	81

RATING DEFINITIONS and CONDITIONS

- Ambient capability factor at 300M (984ft). Consult your local MTU DD Power Generation Distributor for other altitudes.
- Standby ratings apply to installations served by a reliable utility source. The standby rating is applicable to varying loads for the duration of a power outage. No overload capability for this rating. Ratings are in accordance with ISO-3046/1, BS 5514, AS 2789, and DIN 6271.
- Prime power ratings apply to installations where utility power is unavailable or unreliable. At varying load, the number of generator set operating hours is unlimited. A 10% overload capacity is available for one hour in twelve. Ratings are in accordance with ISO-8528/1, overload power in accordance with ISO-3046/1, BS 5514, AS 2789, and DIN 6271. For limited running time and base load ratings, consult the factory.
- Deration Factors:
 - Altitude: Derate 1% per 1,000 ft (305m) above 600 ft (183m).
 - Temperature: Derate 1% per 10°F (5.5°C) above 77°F (25°C).

Weights & Dimensions

	OPU	EPU
Length: in. (cm)	150 (381)	150 (381)
Width: in. (cm)	68 (173)	68 (173)
Height: in. (cm)	90.5 (230)	106.5 (271)
Height w/ Tank: in. (cm)	118.5 (301)	134.5 (342)
Weight (less tank): lb (kg)	7,284 (3,304)	8,741 (3,965)

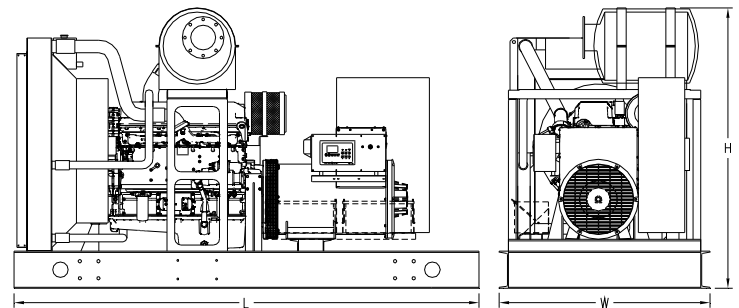

Drawing above for illustration purposes only, based on standard open power 480 volt generator. Lengths may vary with other voltages. *Do Not Use for Installation Design



GeneratorJoe

4016 Quartz Drive
 Santa Rosa, CA 95405
 Phone: 707 539-9003
 Fax: 707 539-5212
 Email: sales@generatorjoe.NET
 Web www.generatorjoe.NET