



# ITS-30R TRANSFER SWITCH OWNER'S MANUAL



## Generator Joe

The ITS-30R provides automatic power switching between two separate 120 volt AC input sources, including powercords, onboard generators, or onboard inverters. The ITS will sense the presence of available supplies and automatically select the proper one.

The ITS can be installed at the electrical entry of the RV on the line side of the main distribution panel, or it can be installed on the load side of the panel between the main panel and a sub panel, allowing switching for either the entire electrical load or only designated circuits.

## INSTALLATION

### READ AND FOLLOW ALL SAFETY INSTRUCTIONS

#### I. DISCONNECT POWER

Make sure the generator is off, the external powercord is unplugged, and the inverter, if any, is shut off.

#### II. MOUNTING LOCATION

The ITS mounting location may be on any interior surface where the unit will be out of direct weather. The chosen location must be accessible after installation is complete to facilitate future servicing. If possible, mount the ITS near the powercord entry or the location of the generator output. Typical locations include under counter cabinets, below closet compartments, inside the bed pedestal or cabinets, overhead cabinets, under-floor storage compartments accessed from the vehicle exterior, etc. **CAUTION: TO PREVENT EXPOSURE TO FOREIGN CONTAMINANTS, DO NOT MOUNT THE TRANSFER SWITCH IN AN ENGINE COMPARTMENT, UNDER KITCHEN SINK DRAINS OR WATER PIPES, WITHIN THE BATTERY COMPARTMENT, OR ANY COMPARTMENT DESIGNED FOR STORAGE OF FLAMMABLE LIQUIDS SUCH AS GASOLINE.**

#### III. ELECTRICAL PREPARATION

Any numbered knockout on the ITS-30R can be used for installation. Choose a knockout that will facilitate installation and service within the selected mounting area.

#### IV. MOUNTING

Mount the ITS-30R with screws through holes in the mounting feet of the unit. The unit should be screwed to a solid surface firmly enough to hold its weight during vehicle operation.



#### V. ELECTRICAL CONNECTIONS

A. Attach an 8 gauge chassis ground wire to the transfer switch ground bar. A direct access hole to the ground bar is provided through the enclosure for convenience.

B. Determine proper connections of wire conductors to electrical terminals. On 120 VAC wiring the ground wire is bare or green, the neutral wire is white, and the hot wire is black.

C. Strip the outer jacket from all of the incoming cables. Strip insulation from all ends of the copper conductors. Insert cables through clamps in openings. Do not tighten cable clamps at this time.

D. Route internal ground wires around lower area of enclosure and secure to ground wires away from electrical contacts on components to avoid the possibility of electrical short-circuit.

E. Connect the ground wires to the ground bar. Tighten terminals to a minimum of 20 inch-pounds.

F. Connect the neutral (white) wire connections.

G. Connect the hot wire(s) (black).

I. To connect the wire leads, hold the wires parallel to each other so that the wire tips are even, then secure with a wire nut. Use the proper size nut. Manually tighten nuts as tightly as possible. Verify that all connections are tightened.

J. Tighten cable clamps on switch enclosure.

K. Attach lid. The lid is designed to snap on and should not open without deliberate effort.

#### INSTALLATION BETWEEN POWERCORD AND GENERATOR (CONFIGURATIONS A, B)

Connect the powercord leads to terminal 7 and 8 (on the narrow end of the relay); these are the *normally closed* (N.C.) contacts. Connect the generator leads to terminals 5 and 6 (on the shoulders of the relay); these are the *normally open* (N.O.) contacts. Connect output to panel to terminals 3 and 4 (on the wide end of the relay). The ITS-30R is designed with a time delay module to provide generators a brief warm-up period before supplying the load. The bypass switch on the time delay module should be in the "off" position (marked "1"). See Diagram 1.

## INSTALLATION BETWEEN INVERTER AND ALTERNATING SOURCE (CONFIGURATION C)

For installation between inverter (default) and another power supply (dominant), such as the output from a prior powercord/generator transfer switch, connect the inverter to terminals 7 and 8, and connect the other power supply to 5 and 6. Output terminals always remain the same. These connections will allow any other supply to dominate the inverter, and the inverter output will pass through the normally closed contacts of the switch. This allows the inverter to operate only in the absence of the other power supplies, which is ideal for inverters. Set the timer delay bypass switch of the inverter/alternate source transfer switch to the ON position. See Diagram 2.

## INSTALLATION IN HYBRID SYSTEM FOR DESIGNATED CIRCUITS (CONFIGURATION D)

The ITS-30R can be installed between inverter (default) and a circuit panel supplied by a larger amp alternating power supply (dominant). Connect the inverter to terminals 7 and 8, and connect the 30 amp branch circuit to 5 and 6. Connect the designated circuit panel to the output terminals. The inverter will only supply the load in the absence of the 50 amp power supply, in which case, only the load designated to the 30 amp branch circuit is supplied. The timer delay bypass switch on the ITS-30R should be in the ON position.

### DIAGRAM 1. TYPICAL GENERATOR/ POWERCORD CONNECTION

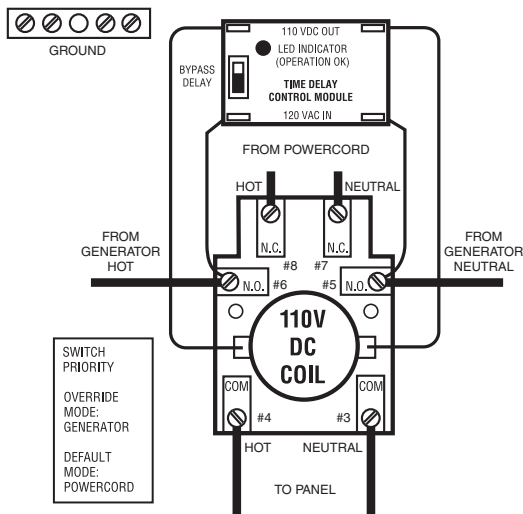

### DIAGRAM 2. TYPICAL INVERTER/ ALTERNATE SOURCE CONNECTION

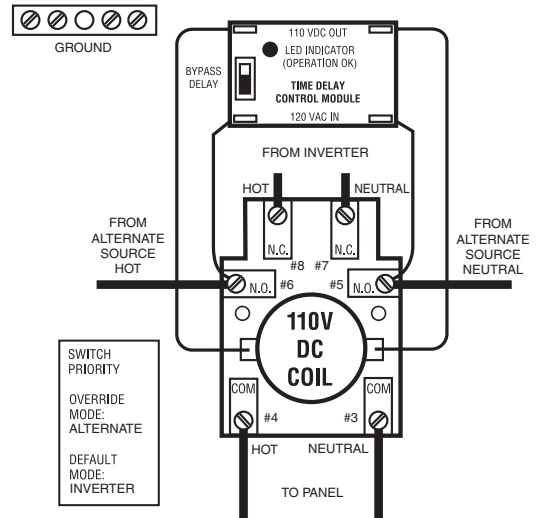

## TYPICAL INSTALLATION CONFIGURATIONS

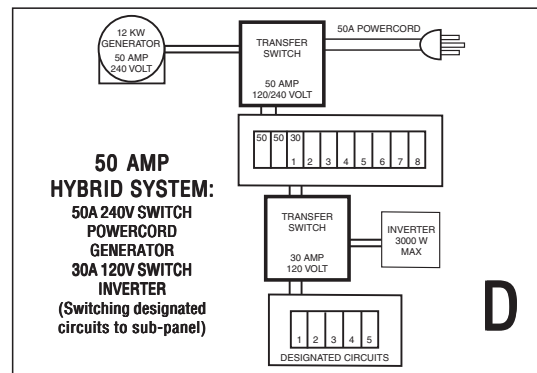
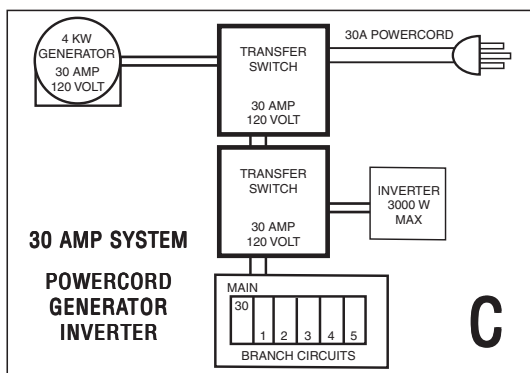
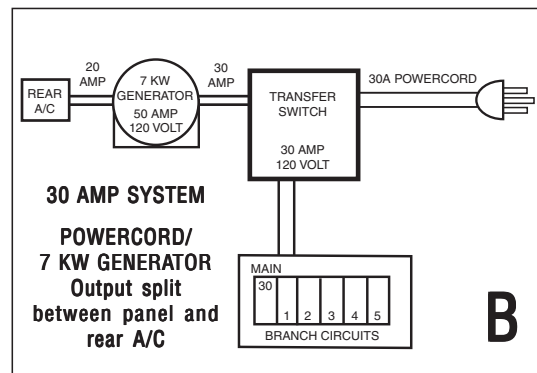
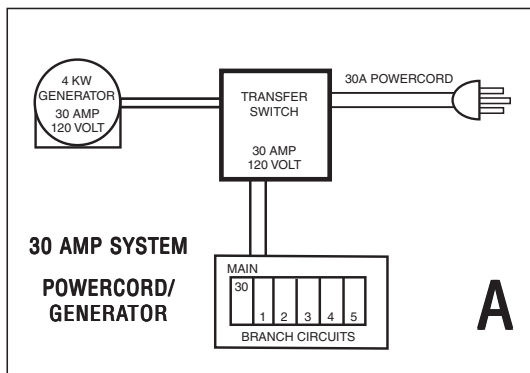

## OPERATIONAL TESTING

### READ AND FOLLOW ALL SAFETY INSTRUCTIONS

I. Plug in the powercord. If the main panel circuit breakers are switched on, RV load should operate normally. Unplug the powercord.

II. Start the generator. There is a pre-programmed 20-30 second delay in the transfer switch. The delay is designed to allow the generator a brief warm-up period. When the delay completes its cycle the switch should engage and the RV load should operate normally. An audible click should sound as the switch engages.

III. Shut down the generator. As the generator winds down the switch should disengage without chatter or cycling. An audible click should sound as the switch disengages.

IV. Plug in the powercord. Start the generator. After the pre-programmed delay, the switch should transfer power automatically from the powercord to the generator. Listen for the audible click as the switch transfers, as there will likely be no other indication that the switch has engaged. Shut down the generator and unplug the powercord.

V. On transfer switch arrangements with three power supplies, plug in the powercord, start the generator, and turn on the inverter. With all three supplies energized at the same time, the switch will select the generator for the primary supply choice. Shut down the generator. The switch will transfer to the powercord. Unplug the powercord. The switch will transfer to the inverter. The inverter should always be connected so that it is only selected in the absence of both the other supplies.

## TROUBLESHOOTING

**I. LOW VOLTAGE:** Low voltage is harmful to most appliances. Contactor-based transfer switches are also affected by low voltage; if the voltage level drops far enough the contactor points will "chatter". Sustained contact chattering can cause transfer switch damage. Switches that have been damaged by chattering need to be returned to the factory for replacement.

**GENERAL LOW VOLTAGE:** Low voltage can be caused by low voltage conditions such as an RV park with inadequate wiring for crowded camper conditions where everyone's electricity suffers (brownout). In this case a voltmeter will be helpful and will show a low voltage reading from the park receptacle, even before the RV is plugged in. When you experience general low voltage conditions, remember, that brownouts can be harmful to most appliances. A better alternative might be to utilize the generator until park voltage conditions improve.

**LOCALIZED LOW VOLTAGE:** Low voltage conditions can be caused by specific situations such as an additional cord which is too long and too small for the load. Do not attempt to extend the RV powercord by using a 16 gauge 100 foot extension cord, or any cord not rated for an RV-size load. A localized low

voltage condition will result when a load is turned on which is larger than that which the cord is designed for. As soon as the RV tries to draw more current than the amount for which the cord is rated, the voltage will fall *within the length of the cord*, and the RV will experience low voltage. This is especially noticeable during inrush current situations such as an air conditioner start-up.

**PHYSICAL INTERFERENCE:** Some transfer switch models have wiring connections made by wire nuts on 6" leads. Occasionally on these models, the wiring connections will get folded into the can in such a manner that the wiring will interfere with the physical operation of the relay. Visually inspect for free operation of the relay(s).

**TIME DELAY BYPASS SWITCH:** The time delay function in the control module on some models may be bypassed. Relay-based transfer switches have incorporated into the control module board a small switch which allows the technician to activate or bypass the time delay. The time delay is necessary during generator start-up so that the generator does not have to start under load; the delay is not necessary for powercords or inverters. Therefore in transfer switch operation where the module is controlling a supply other than a generator, the delay switch should be set to the bypass (ON) position. This will allow instantaneous switching. Another time for bypassing the delay is during diagnostic and troubleshooting efforts; if bypassing the delay causes the switch to work when it otherwise won't, then the time delay has malfunctioned and the board should be replaced. To bypass the time delay, locate the switch on the end of the circuit board and select the position on the switch marked ON. Time delay bypass is now activated, and transfer will be instantaneous.

**FAILED TIME DELAY CONTROL MODULE:** It is possible for a voltage spike, etc. to cause the time delay module to fail: if this happens the switch will no longer transfer. Transfer Switch models have a diagnostic LED mounted on the control module circuit board. If the module is receiving 120 VAC input and is operating properly, the LED will be lit. This means the control module has timed for the 20-30 second delay and is now providing power to the coil on the relay. If the module input is energized and the LED does not light after 30 seconds, the time delay function in the module has failed, and the module should be replaced. To verify this, try setting the time delay switch on the board to the delay bypass position; the switch should transfer with no delay. *Note that this position will allow emergency operation until the module can be replaced; however there will not be a 20-30 second delay for generator start-up.* All repairs should begin by unplugging and replacing the control module first. However, if the LED is on and the switch is not working, then the control module is functioning properly and the switch has other problems, such as a failed relay or contactor, and the entire switch should be returned for replacement.



# Generator Joe

4016 Quartz Drive

Santa Rosa, CA 95405

Phone: 707 539-9003

Fax: 707 539-5212

Email: [sales@generatorjoe.NET](mailto:sales@generatorjoe.NET)

Web [www.generatorjoe.NET](http://www.generatorjoe.NET)

## HI-POT TESTING

### (MANUFACTURING COMPANIES ONLY)

NOTE: If the hi-pot test is performed from the plug on the powercord, the test may only hi-pot the cord itself; it may not test the RV wiring beyond the switch. The hi-pot test should be performed from either the transfer switch *output* or from the main panel. Test as follows:

- I. Turn on all circuit breakers in the panel.
- II. Make sure the generator is off.
- III. Make sure the powercord is unplugged. Verify that the prongs on the powercord plug are protected so that the hi-pot voltage won't cause a fault reading from a short, or cause bodily injury from electrical shock.
- IV. Turn off or disconnect all appliances that would be damaged by the hi-pot test.
- V. Connect the hi-pot leads to:
  - a) Transfer switch ground bar
  - b) Transfer switch output terminals hot 1, hot 2 (if present), and neutral.
- VI. Energize the hi-pot and conduct test. This will hi-pot test for leakage (short) between the current-carrying conductors and the ground in the entire 120/240 VAC circuitry beyond the transfer switch. In most cases it will also test the powercord itself. Turn off the hi-pot.
- VII. **Do not test the transfer switch generator input. The hi-pot will damage the time delay control module in the transfer switch.** If the generator wires to the switch must be checked, disconnect the generator wires from the transfer switch and connect hi-pot test leads to the loose wires. Reconnect wires after testing.
- VIII. If hi-pot test fails, there is a short in the system. The next step is to isolate the location of the short. Turn off the main breaker in panel and hi-pot test again. If the test still fails, the fault is between the switch and the panel. Test cord for shorted plug. If the test passes, turn on the main breaker, and turn on all branch breakers except one. Retest each branch circuit individually until the shorted circuit is isolated. Repair the fault and retest. The hi-pot test is successful when there are no more fault indications.

## GENERATOR NOTE

It is never advisable to start or stop a generator under load. To prolong the life of this transfer switch, and the life of the air conditioner, microwave oven, and other appliances, always turn those appliances off before starting or stopping the generator.

## MEDICAL APPLIANCES

IOTA Engineering L.L.C. will not knowingly sell an ITS Transfer Switch for any life-support application. It is strongly recommended that you do not operate any life support equipment from a transfer switch. If the switch should malfunction, or fail to operate due to other external conditions, it is possible that all connected appliances, including any life support equipment, will also shut down, resulting in a risk of medical complications and potential loss of life.

## CAUTION

Do not install this or any electrical accessory in the battery compartment, or a compartment intended for storing flammable liquids or liquids which produce flammable or explosive fumes such as gasoline, etc. There are components in the Transfer Switch which, in their normal operation, may cause arcing. In addition, the act of turning on a light switch or unplugging the cord on an electrical appliance can cause a spark, which can ignite any combustible liquids or vapors. **Therefore, do not install a transfer switch in a compartment intended for storing flammable liquids, and never store flammable liquids inside a compartment containing any electrical device.**

## WARRANTY

All ITS Series Transfer Switches come with a two-year warranty. IOTA warranties all Transfer Switches in the continental United States and Canada from defects in materials or workmanship under normal use for two years from date of retail purchase and will repair or replace any ITS Transfer Switch under warranty found to be defective free of charge. For complete warranty details, consult Customer Service, or visit [www.iotaengineering.com](http://www.iotaengineering.com)

# IOTA



## GeneratorJoe

4016 Quartz Drive  
Santa Rosa, CA 95405  
Phone: 707 539-9003  
Fax: 707 539-5212  
Email: [sales@generatorjoe.NET](mailto:sales@generatorjoe.NET)  
Web [www.generatorjoe.NET](http://www.generatorjoe.NET)