

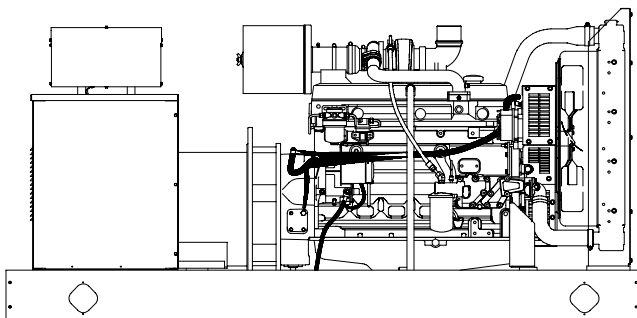

Ratings Range

		60 Hz	50 Hz
Standby:	kW	80-110	70-100
	kVA	80-138	70-110
Prime:	kW	71-100	63-90
	kVA	71-125	63-100



Standard Features

- Kohler Co. provides one-source responsibility for the generating system and accessories.
- The generator set and its components are prototype-tested, factory-built, and production-tested.
- The 60 Hz generator set offers a UL 2200 listing.
- The generator set accepts rated load in one step.
- The generator set complies with ISO 8528-5, Class G2, requirements for transient performance in all generator set configurations. Select the Decision-Maker™ 550 controller for improved voltage regulation and ISO 8528-5, Class G3, compliance.
- A one-year limited warranty covers all systems and components. Two-, five-, and ten-year extended warranties are also available.
- Alternator features:
 - Kohler's Fast-Response™ III wound field (WF) design alternator provides excellent voltage response and short-circuit capability using an auxiliary power brushless exciter.
 - Kohler's unique Fast-Response™ II excitation system delivers excellent voltage response and short circuit capability using a permanent magnet (PM)-excited alternator.
 - The brushless, rotating-field alternator has broadrange reconnectability.
- Other features:
 - Controllers are available for all applications. See controller features inside.
 - The low coolant level shutdown prevents overheating (standard on radiator models only).
 - Integral vibration isolation eliminates the need for under-unit vibration spring isolators.

Generator Set Ratings

Alternator	Voltage	Ph	Hz	130°C Rise Standby Rating		105°C Rise Prime Rating	
				kW/kVA	Amps	kW/kVA	Amps
	120/208	3	60	105/131	364	95/119	330
	127/220	3	60	105/131	344	95/119	312
	120/240	3	60	105/131	316	95/119	286
	120/240	1	60	80/80	333	71/71	296
	139/240	3	60	110/138	331	100/125	301
	220/380	3	60	88/110	167	80/100	152
	277/480	3	60	110/138	165	100/125	150
4S9W/	347/600	3	60	105/131	126	95/119	114
4S9	110/190	3	50	88/110	334	80/100	304
	115/200	3	50	88/110	318	80/100	289
	120/208	3	50	88/110	305	80/100	278
	110/220	3	50	84/105	276	76/95	249
	110/220	1	50	70/70	318	63/63	286
	220/380	3	50	88/110	167	80/100	152
	230/400	3	50	88/110	159	80/100	144
	240/416	3	50	88/110	153	80/100	139
4V11W/	110/220	1	50	100/100	455	90/90	409
4V11	120/240	1	60	110/110	458	100/100	417

RATINGS: All three-phase units are rated at 0.8 power factor. All single-phase units are rated at 1.0 power factor. *Standby Ratings:* Standby ratings apply to installations served by a reliable utility source. The standby rating is applicable to varying loads for the duration of a power outage. There is no overload capability for this rating. Ratings are in accordance with ISO-3046/1, BS 5514, AS 2789, and DIN 6271. *Prime Power Ratings:* Prime power ratings apply to installations where utility power is unavailable or unreliable. At varying load, the number of generator set operating hours is unlimited. A 10% overload capacity is available for one hour in twelve. Ratings are in accordance with ISO-8528/1, overload power in accordance with ISO-3046/1, BS 5514, AS 2789, and DIN 6271. For limited running time and base load ratings, consult the factory. Obtain the technical information bulletin (TIB-101) on ratings guidelines for the complete ratings definitions. The generator set manufacturer reserves the right to change the design or specifications without notice and without any obligation or liability whatsoever. GENERAL GUIDELINES FOR DERATION: *Altitude:* Derate 0.5% per 100 m (328 ft.) elevation above 2000 m (6560 ft.). *Temperature:* Derate 1.0% per 10°C (18°F) temperature above 40°C (104°F).

Alternator Specifications

Specifications	Alternator
Manufacturer	Kohler
Type	4-Pole, Rotating-Field
Exciter type	
Wound field (WF)	Wound Exciter Field with Separate Excitation Power Winding
Permanent magnet (PM)	Brushless, Permanent-Magnet
Leads: quantity, type	12, Reconnectable
Voltage regulator	Solid State, Volts/Hz
Insulation:	NEMA MG1
Material	Class H
Temperature rise	130 °C, Standby
Bearing: quantity, type	1, Sealed
Coupling	Flexible Disc
Amortisseur windings	Full
Voltage regulation, no-load to full-load	
Wound field (WF) alternator	±0.25% Average
Permanent magnet (PM) alternator	±2% Average
550 controller (with 0.5% drift due to temperature variation)	3-Phase Sensing, ±0.25%
One-step load acceptance	100% of Rating
Unbalanced load capability	100% of Rated Standby Current
Peak motor starting kVA:	(35% dip for voltages below)
480 V, 380 V 4S9W/4S9 (12 lead)	320 (60 Hz), 250 (50 Hz)
240 V, 220 V 4V11W/4V11 (4 lead)	350 (60 Hz), 285 (50 Hz)

- NEMA MG1, IEEE, and ANSI standards compliance for temperature rise and motor starting.
- Sustained short-circuit current of up to 300% of the rated current for up to 10 seconds.
- Sustained short-circuit current enabling downstream circuit breakers to trip without collapsing the alternator field.
- Self-ventilated and dripproof construction.
- Vacuum-impregnated windings with fungus-resistant epoxy varnish for dependability and long life.
- Superior voltage waveform from a two-thirds pitch stator and skewed rotor.
- Fast-Response™ III wound field (WF) brushless alternator with auxiliary power brushless exciter for excellent load response.
- Fast-Response™ II brushless alternator with brushless exciter for excellent load response.

Application Data

Engine

Engine Specifications	60 Hz	50 Hz
Manufacturer	John Deere	
Engine model	6068TF250	6068TF220
Engine type	4-Cycle, Turbocharged	
Cylinder arrangement	6 Inline	
Displacement, L (cu. in.)	6.79 (414)	
Bore and stroke, mm (in.)	106 x 127 (4.19 x 5.00)	
Compression ratio	17.0:1	
Piston speed, m/min. (ft./min.)	457 (1500)	381 (1250)
Main bearings: quantity, type	7, Replaceable Insert	
Rated rpm	1800	1500
Max. power at rated rpm, kWm (BHP)	142 (190)	121 (162)
Cylinder head material	Cast Iron	
Crankshaft material	Forged Steel	
Valve material:		
Intake	Chromium-Silicon Steel	
Exhaust	Stainless Steel	
Governor: type, make/model	Mechanical, Stanadyne/DB4	
Frequency regulation, no-load to full-load	3-5%	
Frequency regulation, steady state	±0.33% (mech. governor) ±0.25% (elect. isoch. gov.)	
Frequency	Fixed	
Air cleaner type, all models	Dry	

Exhaust

Exhaust System	60 Hz	50 Hz
Exhaust manifold type	Dry	
Exhaust flow at rated kW, m ³ /min. (cfm)	24.1 (850)	15.7 (553)
Exhaust temperature at rated kW, dry exhaust, °C (°F)	567 (1052)	549 (1020)
Maximum allowable back pressure, kPa (in. Hg)	7.5 (2.2)	
Exhaust outlet size at engine hookup, mm (in.)	98 (3.86)	

Engine Electrical

Engine Electrical System (12/24 Volt*)	60 Hz	50 Hz
Battery charging alternator:	12 Volt/24 Volt	
Ground (negative/positive)	Negative	
Volts (DC)	12/24	
Ampere rating	55/45	
Starter motor rated voltage (DC)	12/24	
Battery, recommended cold cranking amps (CCA):	12 Volt/24 Volt	
Quantity, CCA rating each	One, 800/Two, 570	
Battery voltage (DC)	12	

*12-volt or 24-volt engine electrical systems are available.

Application Data

Fuel

Fuel System	60 Hz	50 Hz
Fuel supply line, min. ID, mm (in.)	11.0 (0.44)	
Fuel return line, min. ID, mm (in.)	6.0 (0.25)	
Max. lift, fuel pump: type, m (ft.)	Engine-Driven, 1.8 (6.0)	
Max. fuel flow, Lph (gph)	113 (29.9)	109 (28.9)
Fuel prime pump	Manual	
Fuel filter	8 Microns @ 98% Efficiency	
Secondary	Yes	
Water Separator	Yes	
Recommended fuel	#2 Diesel	

Lubrication

Lubricating System	60 Hz	50 Hz
Type	Full Pressure	
Oil pan capacity, L (qt.)	19.0 (20.1)	
Oil pan capacity with filter, L (qt.)	19.9 (21.0)	
Oil filter: quantity, type	1, Cartridge	
Oil cooler	Water-Cooled	

Cooling

Radiator System	60 Hz	50 Hz
Ambient temperature, °C (°F)	50 (122)	
Engine jacket water capacity, L (gal.)	11.3 (3.0)	
Radiator system capacity, including engine, L (gal.)	23 (6.1)	
Engine jacket water flow, Lpm (gpm)	186 (49)	159 (42)
Heat rejected to cooling water at rated kW, dry exhaust, kW (Btu/min.)	67.4 (3836)	57.7 (3286)
Water pump type	Centrifugal	
Fan diameter, including blades, mm (in.)	600 (24)	
Fan, kWm (HP)	4.2 (5.6)	2.6 (3.5)
Max. restriction of cooling air, intake and discharge side of radiator, kPa (in. H ₂ O)	0.125 (0.5)	

Remote Radiator System†	60 Hz	50 Hz
Exhaust manifold type	Dry	
Connection sizes:		
Water inlet, ID hose, mm (in.)	51 (2.0)	
Water outlet, ID hose, mm (in.)	64 (2.5)	
Static head allowable above engine, kPa (ft. H ₂ O)	63 (21)	

† Contact your local distributor for cooling system options and specifications based on your specific application.

Operation Requirements

Air Requirements	60 Hz	50 Hz
Radiator-cooled cooling air, m ³ /min. (scfm)‡	178 (6300)	133 (4700)
Cooling air required for generator set when equipped with city water cooling or remote radiator, based on 14°C (25°F) rise, m ³ /min. (scfm)‡	142 (5000)	122 (4300)
Combustion air, m ³ /min. (cfm)	8.6 (302)	6.3 (222)
Heat rejected to ambient air:		
Engine, kW (Btu/min.)	25.9 (1474)	20.5 (1167)
Alternator, kW (Btu/min.)	13.7 (780)	13.4 (760)

‡ Air density = 1.20 kg/m³ (0.075 lbm/ft³)

Fuel Consumption	60 Hz	50 Hz
Diesel, Lph (gph) at % load	Standby Rating	
100%	32.2 (8.5)	25.4 (6.7)
75%	24.2 (6.4)	18.9 (5.0)
50%	16.3 (4.3)	12.9 (3.4)
25%	9.8 (2.6)	7.6 (2.0)
Diesel, Lph (gph) at % load	Prime Rating	
100%	29.1 (7.7)	22.7 (6.0)
75%	22.3 (5.9)	17.4 (4.6)
50%	14.7 (3.9)	12.1 (3.2)
25%	9.1 (2.4)	6.0 (1.8)

Controllers

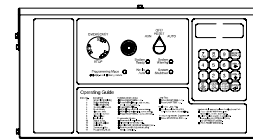

Decision-Maker™ 550 Controller

Audiovisual annunciation with NFPA 110 Level 1 capability. Programmable microprocessor logic and digital display features. Alternator safeguard circuit protection. 12- or 24-volt engine electrical system capability. Remote start, remote annunciation, and remote communication options. Refer to G6-46 for additional controller features and accessories.

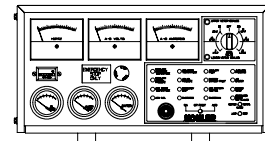

Decision-Maker™ 3+, 16-Light Controller

Audiovisual annunciation with NFPA 110 Level 1 capability. Microprocessor logic, AC meters, and engine gauge features. 12- or 24-volt engine electrical system capability. Remote start, prime power, and remote annunciation options. Refer to G6-30 for additional controller features and accessories.

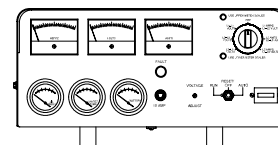

Decision-Maker™ 1 Controller

Single-light annunciation and basic controls with NFPA capability. Relay logic, AC meters, and engine gauge features. 12-volt engine electrical system capability only. Remote or automatic start options. Refer to G6-29 for additional controller features and accessories. **Note:** Not available with 600-volt alternator.

Additional Standard Features

- Alternator Protection (standard with 550 controller)
- Battery Rack and Cables
- Integral Vibration Isolation
- Oil Drain Extension
- Operation and Installation Literature

Available Accessories

Enclosed Unit

- Sound Enclosure (with enclosed critical silencer)
- Weather Enclosure (with enclosed critical silencer)
- Weather Housing (with roof-mounted critical silencer)

Open Unit

- Exhaust Silencer, Critical (kit: PA-354809)
- Exhaust Silencer, Hospital (kit: PA-365349)
- Flexible Exhaust Connector, Stainless Steel

Cooling System

- Block Heater (recommended for ambient temperatures below 0°C [32°F])
- City Water Cooling
- Radiator Duct Flange
- Remote Radiator Cooling

Fuel System

- Auxiliary Fuel Pump
- Flexible Fuel Lines
- Fuel Pressure Gauge
- Subbase Fuel Tanks
- Subbase Fuel Tank with Day Tank

Electrical System

- Battery
- Battery Charger, Equalize/Float Type
- Battery Heater

Engine and Alternator

- Alternator, Wound Field (WF)
- Alternator, Permanent Magnet (PM)
- Air Cleaner, Heavy Duty
- Air Cleaner Restriction Indicator
- Alternator Strip Heater
- Bus Bar Kits
- CSA Certification
- Current Transformer Kit
- Electronic Isochronous Governor ($\pm 0.25\%$ freq. reg. steady state)
- EPA Certified Engine for Tier 2
- Line Circuit Breaker (NEMA type 1 enclosure)
- Line Circuit Breaker with Shunt Trip (NEMA type 1 enclosure)
- Rated Power Factor Testing
- Rodent Guards
- Safeguard Breaker (not available with 550 controller)
- Skid End Caps
- Voltage Regulation, 1%
- Voltage Regulator Sensing, 3-Phase

Paralleling System

- Reactive Droop Compensator
- Voltage Adjust Control
- Voltage Regulator Relocation Kit

Maintenance

- General Maintenance Literature Kit
- Maintenance Kit (includes standard air, oil, and fuel filters)
- NFPA 110 Literature
- Overhaul Literature Kit
- Production Literature Kit

Controller (550 and 16-Light Controllers)

- Common Failure Relay Kit
- Communication Products and PC Software (550 controller only)
- Customer Connection Kit
- Dry Contact Kit (isolated alarm)
- Engine Prealarm Sender Kit
- Prime Power Switch (550 controller only)
- Remote Annunciator Panel
- Remote Audiovisual Alarm Panel
- Remote Emergency Stop Kit
- Remote Mounting Cable
- Run Relay Kit

Miscellaneous Accessories

- _____
- _____
- _____
- _____

Dimensions and Weights

Overall Size, L x W x H, mm (in.):

Wide Skid: 2600 x 1040 x 1274 (102.36 x 40.94 x 50.15)

Narrow Skid: 2600 x 864 x 1274 (102.36 x 34.02 x 50.15)

Weight (radiator model), wet, kg (lb.): 1210-1320 (2660-2900)

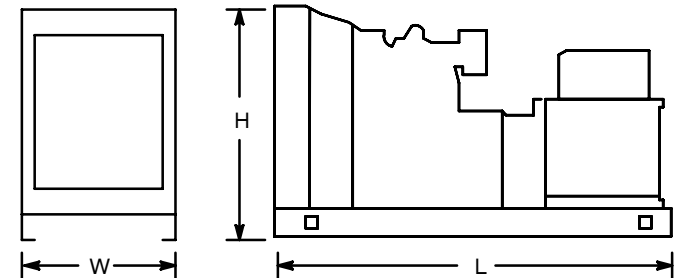

NOTE: This drawing is provided for reference only and should not be used for planning installation. Contact your local distributor for more detailed information.

DISTRIBUTED BY: