



LP Series Portable Load Banks

Compact – Portable – UL Listed

Load Banks Direct, LLC

is a leading manufacturer of high – capacity Load Banks, The LP Series of Portable Indoor Load Banks offers the most robust, high – capacity designs in the industry. LBD is setting the standard with intelligent operator controls, safety indication layouts, adjustable load step resolution, and lightweight designs. The LP Series of portable products is the perfect solution for regularly scheduled maintenance testing and commissioning of mission-critical standby emergency power systems.

- Industry-leading, robust, compact, lightweight designs
- Rated for continuous duty with no cool-down period
- Quick-connect, color-coded Cam-Lok power connectors
- Branch circuit fusing virtually eliminates catastrophic failure
- Intelligent Safety-Circuit, Indicators, and Operator Controls



PowerDyne™ | When Quality Matters

PowerDyne™ Resistors are the most rugged in the industry and can handle the rigors of over-the – road use. They are fully supported across their entire length within the air stream by stainless steel support rods which are insulated with heavy-duty, high-temperature ceramic insulators. Change in resistance is minimized by maintaining conservative resistor designs.



Construction | Built to Last

LBD products are constructed of galvanized steel with the highest quality durable powder – coat paint finish. Portability and ease of positioning are provided with moving handles and heavy – duty casters. Tie – down provisions allow for secure transportation to and from job sites.

Quick Connects | When Time Matters

All LP Series Portable Load Banks come equipped with fully – rated, industry exclusive Cam – Lok power connectors which are color coded for operator safety and ease – of – phase identification. Protective snap – back covers provide added safety during storage and operation

Optional Travel Case



LP100

LP100kW – 240/480VAC – 60Hz



Typical Layout

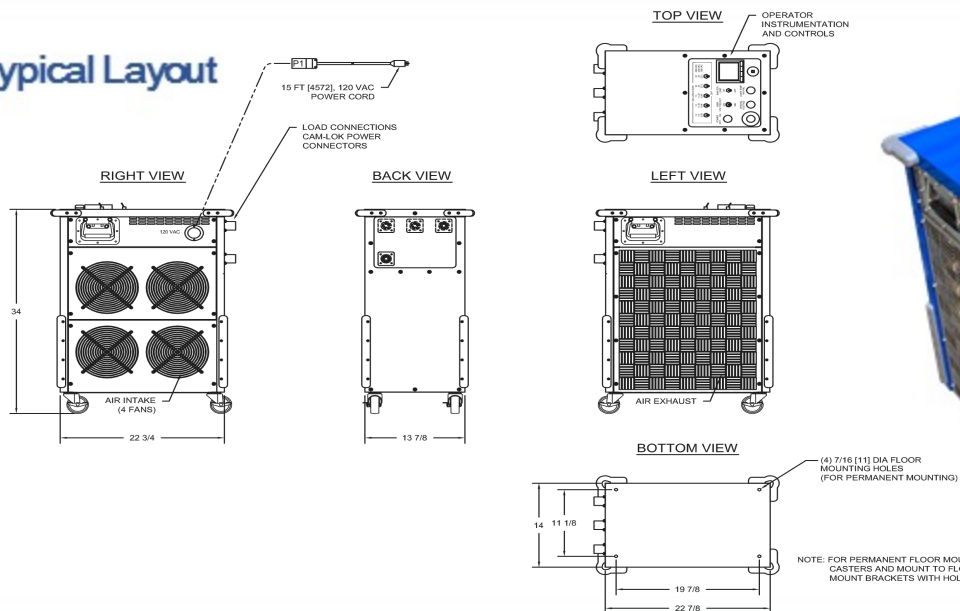

LP100 at 240/480 and 480 Volts AC, 3-Phase, 60Hz

Model	Power Rating (kW)	Voltage (VAC)	Min Load Step (kW)	Dimensions [Width x Depth x Height]	Weight lbs.
LP100	90/100	240/480	10	14" W x 23" D x 34" H	110
LP100	100	480	10	14" W x 23" D x 34" H	100

Cooling System

- ❑ Integrally mounted blower motor with high-performance, direct-driven fan blades delivers the required airflow volume (CFM) for cooling the resistor load elements
- ❑ Blower motors and controls operate from an external 120 VAC, 1-phase, 10 amp power source, A 15' detachable line cord is provided.
- ❑ Motor circuits are short-circuit protected by current-limiting fuses and thermally protected by an overload relay

Standard Digital Power Meter

A fully equipped, 3-phase Digital Power Metering System that measures a standard range of 16 load parameters. Includes RS485 (Modbus protocol) for remote reading – compatible with PC, PLC, and data loggers.



Your Complete Solutions Provider

LBD's complete line of portable and stationary Load Bank products offers industry exclusive load testing solutions for generator set dealer/distributor networks, services arms, rental companies, end users, and original equipment manufacturers of generator sets, UPS systems, turbines, fuel cell, wind power, and battery systems.