

RV generator set

Quiet Diesel™ Series

RV QD 3200



Cummins Onan



Performance you rely on.™

Features and benefits

- Computer-controlled constant speed operation - quiet diesel performance for smaller RVs.
- Special sound-controlling housing encloses cooling system and muffler.
- Double isolation mounting system reduces vibration.
- Easy, accessible maintenance points.
- Runs one rooftop air conditioner with power to spare.
- Integrated start/stop control with hour meter.

Weight, size and sound level

Weight	205 lb	(93 kg)
Length	30.2 in	(766 mm)
Width	17.3 in	(439 mm)
Height	18 in	(453 mm)
Sound	68 dB(A)	(readings at 10 ft (3 m) full load)
	- Meets National Park Service sound level requirements (60 dB(A) @ 50 ft) for national park use.	
	- Typical installation will further reduce sound level.	

Models and ratings

Model	Fan	Hz	Watts	Voltage	Amps	Phase	Circuit protector
3.2 HDZAA-6508A	Internal	60	3200	120	26.7	1	1 pole, 30 A

Ambient conditions for rated power output with muffler and RV enclosure, per ISO 8528-1:

- Temperature: 77° F (25° C)
- Altitude: 500 ft (152.4 m), (99 kPa dry)

Typical power output change based on ambient conditions:

- Temperature: Power output decreases 1% for every 10° F (5.5° C) increase
- Altitude: Power output decreases 3.5% for every 1000 ft (305 m) increase

Ratings represent minimums. Actual performance may be significantly higher based on installation and operating conditions.

Standard features

- 1 cylinder diesel engine
- Permanent magnet alternator
- Digital voltage regulation w/no adjustments required
- Integral enclosed muffler with stationary exhaust pipe connection point
- USDA-approved spark arrestor
- Sound insulated cover with cooling air inlet and outlet ducts
- Heavy-duty air cleaner
- Automotive type starter
- Hour meter
- Meets applicable U.S. EPA and California emissions standards
- Connector for remote operation
- Double Isolation mounting system
- Terminal block connection for AC output
- Electric fuel pump
- Fuel filter
- Cleanable oil screen filter
- Service and maintenance through service doors
- Pure Sine

Average fuel consumption:

Diesel	No load	Half load	Full load
3.2 HDZAA	0.2 Gal/h (0.7 L/h)	0.3 Gal/h (1.0 L/h)	0.4 Gal/h (1.4 L/h)

Alternator details

Design: Permanent magnet

Brushes: None

Exciter system: None

Cooling: Direct drive centrifugal blower; cast aluminum housing for excellent heat transfer

Control system

Microprocessor control

User and service personnel accessible diagnostics

Over voltage, over speed and overload safety

Low oil pressure safety

AC alternator over temp safety

Automatic timed glow plugs

One touch stop

Integrated display with start/stop switches and LCD

Engine details

Design: 4-cycle, air-cooled diesel engine

Cylinders: 1, vertical

Bore: 3.15 in (80.0 mm)

Stroke: 2.72 in (69 mm)

Displacement: 21.16 in³ (347 cm³)

Compression ratio: 22 to 1

Lube oil capacity: 1.2 qt (1.1 L)

Generator set performance

Voltage regulation no load to full load: ± 8%

Frequency regulation no load to full load:
± 0.1% THD: <5%

Air conditioner operation: Will operate with one 13500 Btu air conditioner and an additional load up to 1000 W at 100° F and 500 ft (152.4 m) altitude

Basic dimensions

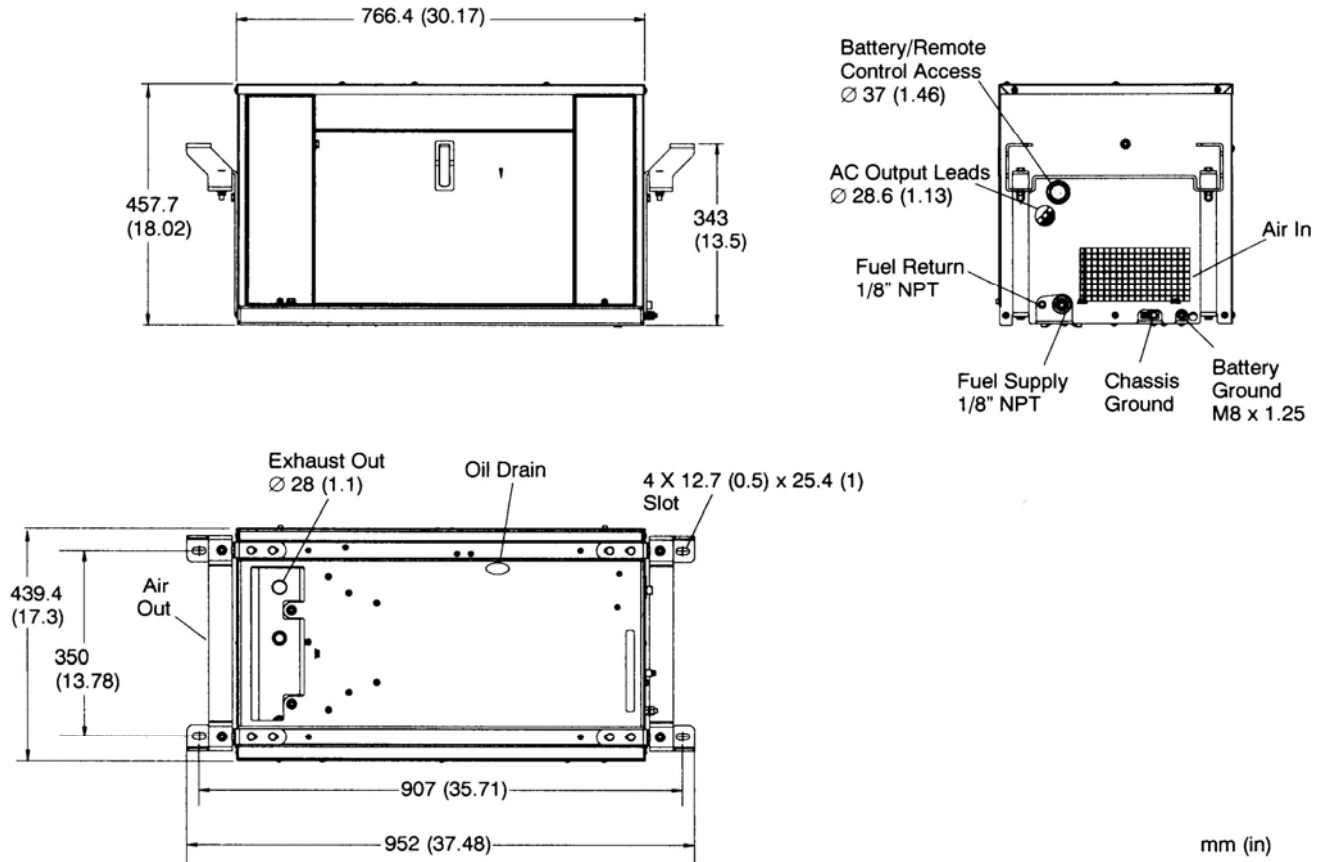

Note: This outline drawing is provided for general reference only and is not intended for design or installation. For more information see Operation and Installation manuals or obtain 500-4709 drawing and wiring diagram from your distributor/dealer.

Testing for RV application

- Tested at extremes of temperature -20° F (-29° C) to 120° F (49° C) for starting and operation
- Tested with RV loads, air conditioners, microwaves, converter, TVs, VCRs
- Tested installed. Cummins Onan RVs used for product development testing
- Tested in high humidity conditions
- Tested in salt spray conditions
- Tested in heavy airborne dust conditions
- Field test program
- 60 Hz (120 V only) models listed by SGS United States Testing Company, Inc. per ANSI/RVIA EGS-1 and CSA-certified by Std. 100 Motors and Generators and TIL RV-06
- This generator set was designed and manufactured in facilities certified to ISO 9001
- 60 Hz models meet applicable U.S. EPA and California emissions standards



Warranty policy

This limited warranty covers virtually everything except routine maintenance for the first two years you own your RV generator set, and covers parts and labor on major power train and generator set parts during the third year. In addition, it also includes a free 90-day adjustment policy, which provides that Cummins Inc. will make minor adjustments during the first three months you own it - free of charge! Please note: This 3-year limited warranty applies to RV generator sets used in RV applications only, and does not apply to RV generator sets used in commercial mobile applications.

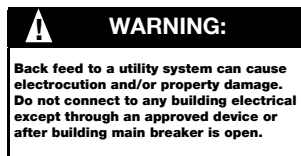
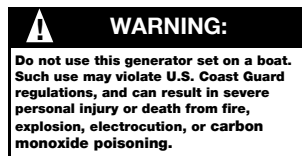

After sale support

Complete line of parts and accessories

Cummins Inc offers replacement and tune-up parts, accessories, oil and maintenance chemicals - all specially designed to help keep your Cummins Onan generator set running at peak performance. Cummins Inc. also provides genuine Onan Green Label Parts™ that exactly match generator set specifications and will help maximize power output and extend the life of your generator set.



Largest distributor/dealer support network

Cummins Onan generator sets are supported by the largest and best trained worldwide certified distributor/dealer network in the industry. This network of knowledgeable Cummins Onan distributor/dealers will help you select and install the right generator set and accessories to meet the requirements of your specific application. This same network offers a complete selection of commonly used generator set maintenance parts, accessories and products plus manuals and specification sheets. Plus, they can answer your questions regarding proper operation, maintenance schedules and more.

Manuals: Operation and installation manuals ship with the generator set. To obtain additional copies or other manuals for this model, see your Cummins Onan distributor/dealer and request the following manual numbers: Operation (983-0103), Installation (983-0602), Parts (983-0203), Service (983-0502).

To easily locate the nearest Cummins Onan distributor/dealer in your area, or for more information, contact us at 1-800-888-6626 (or 763-574-5000), or visit www.cumminsonan.com.

Contact your distributor/dealer for more information

Cummins Onan

Cummins Power Generation

1400 73rd Ave. NE
Minneapolis, MN 55432 USA
Phone 1 763 574 5000
Toll-free 1 800 888 6626
Fax 1 763 574 5298
Email www.cumminsonan.com/contact
www.cumminsonan.com

