



EPA-Certified for Prime Power and Standby Applications

Towable Generator Set

- Kohler Co. provides one-source responsibility for the generating system and accessories.
- The generator set and its components are prototype-tested, factory-built, and production-tested.
- A three-year, 3000-hour limited warranty covers all generator set systems and components. The trailer has a one-year limited warranty.
- Generator set features:
 - Unit-mounted radiator with 45°C (113°F) ambient air capability.
 - The unique Fast-Response™ X excitation system delivers excellent voltage response and short-circuit capability using a rare-earth, permanent magnet (PM)-excited alternator.
 - The brushless, rotating-field alternator has broadrange reconnectability when ordered without a selector switch.
- Engine features:
 - Operates on LP gas, LP liquid withdrawal, or natural gas fuel supply.
 - Heavy-duty air cleaner with air restrictor indicator.
 - Lockable battery disconnect switch.
 - Electronic, isochronous governor.
- Enclosure and trailer features:
 - Durable steel, sound-attenuating housing with quiet operation of 66 dB(A) @ 7 m (23 ft.) (full load).
 - Stainless steel hinges and lockable latches on doors.
 - 110% environmental containment basin for oil and coolant.
 - Single-axle trailer with electric brakes and battery back-up breakaway system.
 - Single-point lifting eye and four-point tie down system for detaching the generator set and fuel tank from the trailer.
- Customer connection panel features:
 - Decision-Maker® 3500 controller features potted circuitry for protection from vibration and debris.
 - Externally mounted, recessed emergency stop switch.
 - Adjustable trip main line circuit breaker.
 - Remote start/stop capabilities.
 - Load lug connections (see page 3 for details).
 - Shore power connection point for block heater and battery charger.

Ratings Range

		60 Hz
Standby:	kW	28
	kVA	28-35
Prime:	kW	25
	kVA	25-31

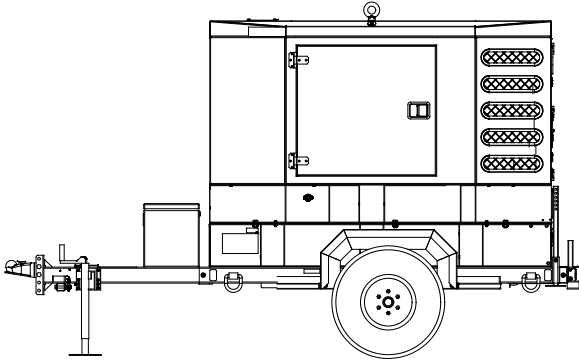

- Convenience Package (see page 4 for all available options):
 - 24-hour on-board LP tank assembly
 - Battery charger
 - Camlock style load connectors, color coded
 - Cold weather package (includes block heater and battery heater pad and wrap)
 - Duplex receptacles, two 120 V, 15 amp
 - Twistlock receptacles, three 240 V, 50 amp
 - Voltage selector switch, 3-position lockable

Generator Set Ratings

Alternator	Voltage	Ph	Hz	LP Gas 150°C Rise Standby Rating		LP Gas 125°C Rise Prime Rating		Natural Gas 150°C Rise Standby Rating		Natural Gas 125°C Rise Prime Rating		Ordering Options*
				kW/kVA	Amps	kW/kVA	Amps	kW/kVA	Amps	kW/kVA	Amps	
4P5X	120/208	3	60	28/35	97	25/31	86	28/35	97	25/31	86	A
	120/240	3	60	28/35	84	25/31	75	28/35	84	25/31	75	B
	120/240	1	60	28/28	116	25/25	104	28/28	116	25/25	104	A
	277/480	3	60	28/35	42	25/31	37	28/35	42	25/31	37	A
	347/600	3	60	28/35	33	25/31	30	28/35	33	25/31	30	C

* Ordering Options: A-Reconnectable or selector switch, B-Reconnectable, C-Stand alone

RATINGS: All three-phase units are rated at 0.8 power factor. All single-phase units are rated at 1.0 power factor. Standby Ratings: The standby rating is applicable to varying loads for the duration of a power outage. There is no overload capability for this rating. Prime Power Ratings: At varying load, the number of generator set operating hours is unlimited. A 10% overload capacity is available for one hour in twelve. Ratings are in accordance with ISO-8528-1 and ISO-3046-1. Obtain technical information bulletin (TIB-101) for ratings guidelines, complete ratings definitions, and site condition derates. The generator set manufacturer reserves the right to change the design or specifications without notice and without any obligation or liability whatsoever.

Alternator Specifications

Specifications	Alternator
Manufacturer	Kohler
Type	4-Pole, Rotating-Field
Exciter type	Brushless, Rare-Earth Permanent Magnet
Leads: quantity, type	12, Reconnectable
Voltage regulator	Solid State, Volts/Hz
Insulation:	NEMA MG1
Material	Class H
Temperature rise	150°C, Standby/ 125°C, Prime
Bearing: quantity, type	1, Sealed
Coupling	Flexible Disc
Amortisseur windings	Full
Voltage regulation, no-load to full-load	±0.5%
One-step load acceptance	100% of Rating
Unbalanced load capability	100% of Rated Standby Current
Peak motor starting kVA @ 0.3 PF:	(35% dip for voltages below)
480 V	4P5X (12 lead)
	136 (60 Hz)

- NEMA MG1, IEEE, and ANSI standards compliance for temperature rise and motor starting.
- Sustained short-circuit current of up to 300% of the rated current for up to 10 seconds.
- Sustained short-circuit current enabling downstream circuit breakers to trip without collapsing the alternator field.
- Self-ventilated and drip-proof construction.
- Windings are vacuum-impregnated with epoxy varnish for dependability and long life.
- Superior voltage waveform from a two-thirds pitch stator and skewed rotor.
- The unique Fast-Response® X excitation system delivers excellent voltage response and short-circuit capability using a rare-earth, permanent magnet (PM)-excited alternator.

Application Data

Engine

Engine Specifications	
Manufacturer	General Motors
Engine: model, type	Industrial Powertrain 3.0 L, 4-Cycle Natural Aspiration
Cylinder arrangement	4 Inline
Displacement, L (cu. in.)	3.0 (181)
Bore and stroke, mm (in.)	101.6 x 91.4 (4.00 x 3.60)
Compression ratio	8.2:1
Piston speed, m/min. (ft./min.)	329 (1080)
Rated rpm	1800
Max. power at rated rpm, kW (HP)	
LP Gas	31.3 (41.9)
Natural Gas	31.3 (41.9)
Valve (exhaust) material	Forged Steel
Governor type	Electronic
Frequency regulation, no-load to full-load	Isochronous
Frequency regulation, steady state	±0.5%
Air cleaner type, all models	Dry

Exhaust

Exhaust System	
Exhaust manifold type	Dry
Exhaust flow at rated kW, m ³ /min. (cfm)	7.1 (250)
Exhaust temperature at rated kW, dry exhaust, °C (°F)	688 (1270)
Maximum allowable back pressure, kPa (in. Hg)	10.2 (3.0)

Engine Electrical

Engine Electrical System	
Ignition system	Electronic, Distributor
Battery charging alternator:	
Ground (negative/positive)	Negative
Volts (DC)	12
Ampere rating	70
Starter motor rated voltage (DC)	12
Battery, recommended cold cranking amps (CCA):	
Qty., rating for -18°C (0°F)	One, 630
Battery voltage (DC)	12

Fuel

Fuel System		
Fuel type	Natural Gas, LP Gas, or LP Liquid Withdrawal	
Fuel supply line inlet (gas)	1.25 NPTF	
Fuel supply line inlet (LP liquid)	3/8 NPTF	
Natural gas fuel supply pressure, kPa (in. H ₂ O)	1.74–2.74 (7-11)	
LP Gas vapor withdrawal fuel supply pressure, kPa (in. H ₂ O)	1.24–2.74 (5-11)	
Fuel Composition Limits *	Nat. Gas	LP Gas
Methane, % by volume	90 min.	1.2 max.
Ethane, % by volume	4.0 max.	10 max.
Propane, % by volume	1.0 max.	96 max.
Propene, % by volume	0.1 max.	3 max.
C ₄ and higher, % by volume	0.3 max.	3 max.
Sulfur, ppm mass	25 max.	
Lower heating value, MJ/m ³ (Btu/ft ³), min.	33.2 (890)	78.8 (2116)

* Fuels with other compositions may be acceptable. If your fuel is outside the listed specifications, contact your local distributor for further analysis and advice.

Lubrication

Lubricating System	
Type	Full Pressure
Oil pan capacity, L (qt.)	3.8 (4.0)
Oil pan capacity with filter, L (qt.)	4.1 (4.3)
Oil filter: quantity, type	One, Cartridge

Cooling

Radiator System	
Radiator system capacity, including engine, L (gal.)	14.9 (3.9)

Operation Requirements

Air Requirements	
Radiator-cooled cooling air, m ³ /min. (scfm)‡	105 (3700)
Combustion air, m ³ /min. (cfm)	2.1 (74)
Heat rejected to ambient air:	
Engine, kW (Btu/min.)	16.0 (910)
Alternator, kW (Btu/min.)	3.8 (220)

‡ Air density = 1.20 kg/m³ (0.075 lbm/ft³)

Application Data

Fuel Consumption ‡

LP Gas, m ³ /hr. (cfh) at % load	Standby Ratings	Prime Ratings
100%	4.7 (167)	4.4 (154)
75%	3.9 (136)	3.6 (126)
50%	3.0 (104)	2.8 (97)
25%	2.0 (71)	1.9 (68)

Natural Gas, m ³ /hr. (cfh) at % load	Standby Ratings	Prime Ratings
100%	11.5 (405)	10.4 (369)
75%	9.1 (322)	8.4 (297)
50%	6.9 (245)	6.5 (229)
25%	4.9 (174)	4.7 (167)

‡ Nominal fuel rating: Natural gas, 37 MJ/m³ (1000 Btu/ft.³)
LP vapor, 93 MJ/m³ (2500 Btu/ft.³)

LP vapor conversion factors:

8.58 ft.³ = 1 lb.
0.535 m³ = 1 kg.
36.39 ft.³ = 1 gal.

Controller

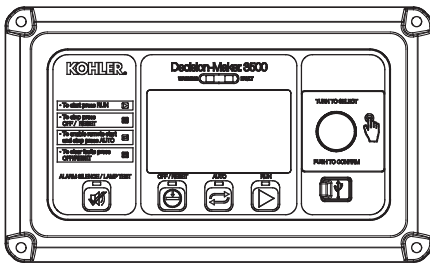

Decision-Maker[®] 3500 Paralleling Controller

Provides advanced control, system monitoring, and system diagnostics for optimum performance and compatibility.

- Paralleling capability with bus sensing, first-on logic, synchronizer, and (isochronous, droop, and external controlled) load sharing
- Digital display with adjustable contrast and menu control provide easy local data access
- Measurements are selectable in metric or English units
- Remote communication thru a PC via network or serial configuration
- Controller supports Modbus[®] protocol
- Integrated hybrid voltage regulator with $\pm 0.5\%$ regulation
- Potted circuitry for protection from vibration and debris
- Built-in alternator thermal overload protection
- NFPA 110 Level 1 capability

Available Voltage Selector Switch

(Available Options, see page 4)

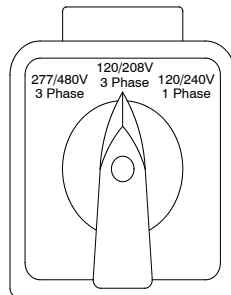

3-Position

- Voltage selector switch, 3-position lockable, wired for:
 - 120/240 volt, 1 phase
 - 120/208 volt, 3 phase
 - 277/480 volt, 3 phase

Modbus[®] is a registered trademark of Schneider Electric.

Power Panel

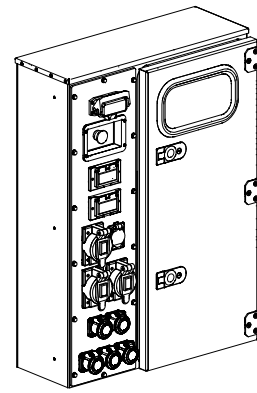

- Viewable generator set controller with security cover
- Emergency stop switch
- Shore power connector, 120 V, 15 amp (for battery charger and block heater)
- Remote start connection
- Mobile paralleling box connection
- Main line circuit breaker
 - Reconnectable models: Rating 150 amps, field adjustable based on voltage selected
 - 600 volt models: Rating 60 amps, field adjustable
- Available Options, see page 4
 - Two 15-amp 120 V, 1 phase, GFCI duplex receptacles (includes circuit breakers)
 - Three 50-amp 240 V twistlock receptacles (includes circuit breakers)
 - Color-coded camlock connections

Load Lug Connections, Qty., Min./Max.

1 load lug per phase #6-350MCM, 400 amp

Trailer

- Single-axle trailer with electric brakes and battery back-up breakaway system.
- DOT and TC (Transport Canada) compliant per current specifications published by both agencies, at the time of trailer manufacture.
- 2 5/16 in. ball hitch coupler with adaptability for an optional Lunette eye.
- Lockable utility tool box with bottle jack, lug wrench, and fire extinguisher. Common key to enclosure.
- Running lights with 7-wire harness and connector.
- Front tongue jack.
- Rear stabilizer trailer jacks.
- Weight bearing fenders up to 227 kg (500 lbs.).

Trailer Specifications

Axle Rating	Single, 2359 kg (5200 lb.) axle
Tires	ST225/75R15 LRD with 1152 kg (2540 lb.) load rating
Wheels	Steel, 15 x 6, 6-bolt

Available Fuel Tank

(Available Options–Fuel Tank, see page 4)

- Trailer-mounted LP fuel tanks for 24-hour run time (minimum).
- Lockable fuel tank access doors to each tank fill port.
- Tank assembly fuel level is shown on the DEC 3500 controller display.

Fuel Tank Specifications

Fuel Tank, qty. capacity	Two, 161 L (42.5 gal.) at 80% full
Fuel Tank, total capacity	322 L (85 gal.) at 80% full

Standard Features

- Alternator Protection
- Battery, Battery Rack, and Battery Cables
- Engine Oil and Coolant Added
- Gaseous Fuel System (includes fuel mixer, electronic secondary gas regulator, gas solenoid valve, and flexible fuel line between the engine and the skid-mounted fuel system components)
- Integral Vibration Isolation
- Local Emergency Stop Switch
- LP Liquid Fuel Filter
- LP Liquid Withdrawal (vaporizer)
- Oil Drain Extension
- Operation Literature
- Three-Way Exhaust Catalyst
- Three-Way Fuel Valve
 (for connection of a user-supplied external fuel source)

Literature

- General Maintenance
- NFPA 110
- Overhaul
- Production

Other Options

- _____
- _____
- _____
- _____
- _____
- _____
- _____

Available Options

Controller

- 15-Relay Dry Contact

Electrical System

- Battery Charger, Equalize/Float Type
- Cold Weather Package
 (includes block heater and battery heater pad and wrap)
- Voltage Selector Switch, Lockable

Fuel Tank

- 24-Hour On-Board LP Tank Assembly

Paralleling System

- Mobile Paralleling Box

Power Panel

- Camlock Style Load Connectors, Color Coded
- Convenience Receptacles (3-240 volt, 2-120 volt)
 (includes individual circuit breakers)

Trailer

- Lunette Eye (for pintle hitch tow vehicles)
- Spare Tire
- Wheel Chock Blocks

Miscellaneous

- Spark Arrestor

Dimensions and Weights

Overall Size, L x W x H, mm (in.): 3680 x 1867 x 2160
 With fuel tank (144.9 x 73.5 x 85.0)
 Weight with engine fluids and no fuel in tank, kg (lb.): 1677 (3690)

Overall Size, L x W x H, mm (in.): 3680 x 1867 x 1707
 Without fuel tank (144.9 x 73.5 x 67.2)
 Weight with engine fluids, kg (lb.): 1381 (3038)

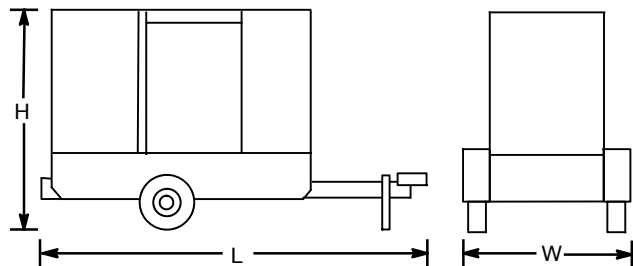

Note: This drawing is provided for reference only and should not be used for planning. Contact your local distributor for more detailed information.

DISTRIBUTED BY: