



CMM EFI 5500 GenSet

GeneratorJoe

4016 Quartz Drive
Santa Rosa, CA 95405
Phone: 707 539-9003
Fax: 707 539-5212
Email: sales@generatorjoe.NET
Web www.generatorjoe.NET

Gasoline
5.5 kW 60 Hz



Commercial GenSet

- First EFI (Electronic Fuel Injection) GenSet in its Class
- EFI Provides Improved Hot and Cold Start Capability
- Integrated Hydraulic Pump Option (pictured)
- Quietest and Lowest Vibration GenSet in Its Class
- Integrated Housing Design
- Enclosed Muffler for Ease of Installation
- Self-Diagnostic Capability to Simplify Troubleshooting
- Runs Two ACs
- Digital Regulation for Voltage Stability as Loads Change
- Electronic Governor for Voltage Stability and Frequency Control
- 2-Year Limited Warranty, 5-Year Drive Warranty

Models and Ratings

Model	Fuel	Hz	Watts	Voltage	Amps	PF	Phase	Circuit Breaker
5.5 HGJAD-2138A+	Gasoline	60	5500	120	45.8	1.0	1	2 pole, 30 Amp
5.5 HGJAD-2243A*+	Gasoline	60	5500	120	45.8	1.0	1	2 pole, 30 Amp
5.5 HGJAD-2140A+	Gasoline	60	5500	120/240	22.9	1.0	1	2 pole, 30 Amp
5.5 HGJAD-1911A*+	Gasoline	60	5500	120/240	22.9	1.0	1	2 pole, 30 Amp
5.5 HGJAD-2142A+	Gasoline	60	5500	120/240	13.2	1.0	3	3 pole, 18 Amp

*Hydraulic pump standard
+Must order fuel return kit with genset (see F-1106, Onan Commercial Mobile Accessories and Service Support Catalog.
All 60 Hz models operate at 2400 r/min.
Ratings apply to altitudes up to 500 ft (152.4 m) 85° F (29.4° C).
Derating: power output will decrease 3.5% for each 1000 ft (305 m) above sea level and 1% for each 10° F (5.5° C) increase in ambient temperature above 85° F (29° C).

Weight, Size and Sound Level

- 290 lb (132 kg)
- Length 33.6 in (853 mm), Width 22.2 in (563 mm), Height 16.7 in (425 mm)
- 60 Hz, 64 dB(A) at 10 ft (3 m), typical installation, full load



GeneratorJoe

4016 Quartz Drive
Santa Rosa, CA 95405
Phone: 707 539-9003
Fax: 707 539-5212
Email: sales@generatorjoe.NET
Web www.generatorjoe.NET

Standard Features

- Electronic Fuel Injection (EFI) for clean, smooth running under all conditions
- Electronic governor
- Onan Performer™ OHV engine
- Pressurized Thru Flow cooling system
- 4-point mounting system with coil spring vibration isolators
- Universal mounting tray with structural capability to support the genset in commercial mobile applications
- Integral USDA Forest Service-approved spark-arrestor muffler
- Integral control box
- Instant one-touch stop switch
- Electronic ignition
- Self diagnostic capability
- Hour meter
- Battery charging - 10 amps
- Remote disable/continuous stop
- Start and run without AC output - engine run only
- Enclosed muffler provides noise reduction and ease of installation
- Sound-attenuated housing
- Waterproof remote connector
- Heavy-duty solenoid shift starter
- Long-life fuel filter
- Spin-on, full-flow oil filter
- Low oil pressure protection
- Overspeed/underspeed protection
- Low power factor field overcurrent protection
- Digital voltage regulation
- Hydraulic pump standard on some models
- 36 in generator output leads

Accessories

- Remote control start/stop rocker switch (part #300-5331)
- Remote control with start/stop switch and hour meter (part #300-5332)
- Remote control with start/stop switch and DC voltmeter (part #300-5333)
- Remote control plug and wire harness 10 ft (part #338-3489-01), 30 ft (part #338-3489-02)
- Remote harness (300-4946) pigtail harness to connect to sealed remote connector
- Battery, 12 V, 380 cold cranking amps at 0° F (-18° C) (part #416-0579) (dry)
- Underfloor mounting kit (part #405-6699)
- Installation template (part #539-2057)
- Tailpipe kit 22 in (part #155-3481-01), 26 in (part #155-3481-02)
- Exhaust tube, straight with flanged end 3 in (part #155-2610), 7 in (part #155-2424), 12.5 in (part #155-2610-01)
- Exhaust elbow, tight radius 90° to route exhaust through cutouts (part #155-3439)
- Fuel system kit for Ford truck (F350/450/550 cab chassis) (part #541-0671)
- Fuel system kit for GM truck (Silverado cab chassis) (part #541-0672)
- Fuel system kit for Ford van (Econoline E250/E350) (part #541-0673)
- Basic universal fuel pump kit (customer must supply pressure hoses (SAE J30 R9), clamps, etc.) (part #147-0870-02)

Basic Dimensions

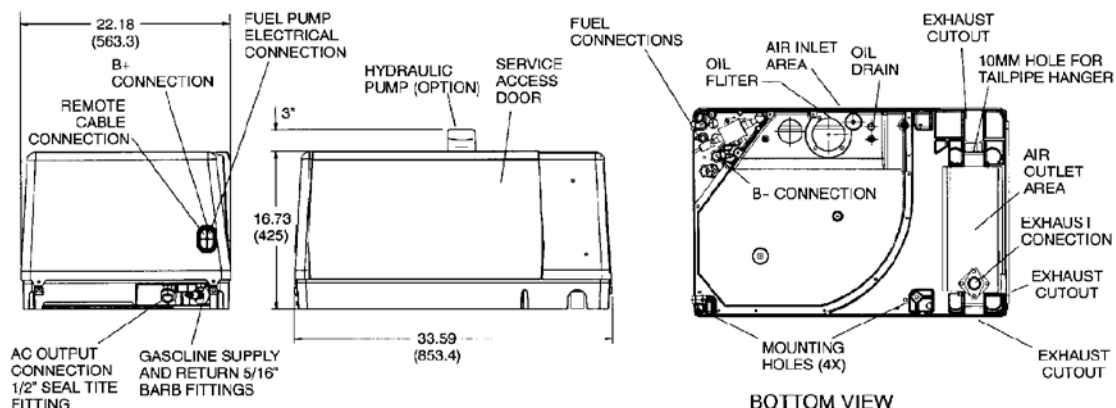

This outline drawing is provided for general reference only and is not intended for design or installation. For more information see installation manual or obtain outline drawing 500-3449 and wiring diagram from your Distributor/Dealer.

Engine Detail

Model: Onan Performer™ OHV EH65V gasoline engine

Design: 4-cycle, OHV, 90-degree V-Twin

Cylinders: 2

Bore: 80 mm

Stroke: 65 mm

Displacement: 39.8 in³ (653 cm³)

Compression ratio: 8:1

Oil capacity: 2.0 qt (1.9 L) including filter

Power (max): at 2400 r/min: 11.6 hp

Cooling: Centrifugal blower, generator-mounted for high effectiveness, pressurized system, vertical flow

Cooling air volume: 60 Hz: 500 ft³/min. (14.2 m³/min) at 2400 r/min. Air flow includes engine, generator, and control cooling air flow

Fuel system:

- Replaceable dry element air cleaner

- Gasoline - sidedraft throttle body

- Remote mount electronic fuel pump with positive fuel shutoff (45 psi), maximum fuel lift 3 ft (0.9 m)

- Combustion air volume: 60 Hz: 17.2 ft³/min (0.53 m³/min) at 2400 r/min

Typical fuel consumption

Gasoline, Gal/hr (L/hr)

	No load	Half load	Full load
5.5 HGJAD	0.35 (1.3)	0.60 (2.3)	0.95 (3.6)

Starting System: Remote, 12 V, negative ground; automotive type starter with steel pinion and ring gear, automatic start disconnect, connector for remote start cable, start-stop rocker switch mounted on set control

Ignition System: Electronic magneto type with resistor plugs

Lubrication: Full pressure positive displacement lube oil pump, spin-on, full flow lube oil filter, low oil pressure shutdown, dipstick

Cylinder-crankcase: Alloy aluminum with iron cylinder liners cast into the block, aluminum oil base

Cylinder head: Aluminum, overhead valve, removable

Alternator Detail

Design: Onan, revolving field, AC, 2-pole self-excited, two bearing design

Insulation system and temperature rise: Meets requirements of NEMA, MG-1 and CSA C22.2, No. 100, Motors and Generators

Cooling: Direct drive centrifugal blower, cast aluminum housing for excellent heat transfer

Rotor: Laminated electrical steel assembly press-fitted to shaft, balanced; heavy insulated copper wire windings; optimized air gap for improved waveform and motor starting; class 200 magnet wire

Stator: Laminated electrical steel assembly, skewed for improved waveform; class 200 quadrature wire with 70% more insulation over comparable gensets

Excitation: Capped, digital voltage regulation

DC Brushes: Electrographic; long life
Bearing: Double-sealed prelubricated ball bearings

GenSet Detail

	No load - full load	Constant load
Frequency regulation	1.7%	1.7%
Voltage regulation	2.0%	1.7%

Hydraulic pump

Fixed displacement gear pump, 1.5 Gal/min at 2500 psi



GeneratorJoe

4016 Quartz Drive
Santa Rosa, CA 95405
Phone: 707 539-9003
Fax: 707 539-5212

Email: sales@generatorjoe.NET
Web www.generatorjoe.NET

Warranty Policy

The ONAN limited warranty covers virtually everything except routine maintenance for the first two years that you own your generator set, or the first 2,000 hours of operation, whichever comes first; five years on drive system. In addition, it includes a free 90-day adjustment policy, which provides that Onan will make minor adjustments to your new genset during the first three months you own it - free of charge!

For complete Onan limited warranty details see your certified Onan Distributor/Dealer.

After Sale Support

EASY TO LOCATE CERTIFIED ONAN SERVICE AND PARTS DEALERS - Onan has the largest and best-trained worldwide certified Distributor/Dealer network in the industry, offering on-time parts and service, and installation assistance. Cummins Onan Distributor/Dealers stock and sell commonly used Onan GenSet maintenance parts, accessories and products, plus operator manuals and literature on current Onan GenSets. They can help you select and install the right genset or accessories on older models, or provide answers to questions on proper operation and maintenance procedures.

MANUALS - Installation and operators manuals are shipped with the genset. To obtain additional copies or other manuals for this model, see your Cummins Onan Distributor/Dealer and request the following part numbers: Operators Manual (983-0102), Parts Manual (983-0202), Service Manual (983-0501), and Installation Manual (983-0601).

Standards and Testing

Tested at extremes of temperature -20° F to 120° F for starting and operation. Tested installed.

Tested with commercial loads.

Tested in high humidity conditions.

Tested in salt spray conditions.

Tested in heavy air borne dust conditions.

Field Test Program.

This generator set meets exhaust emissions regulations for U.S. EPA Phase 2 and California MY 2002-MY-2005 for small off-road engines.

This generator set was designed and manufactured in facilities certified to ISO 9001.

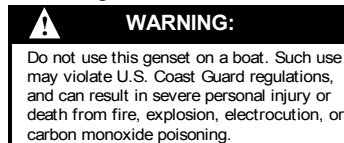

Contact your Distributor/Dealer for more information:

The Onan logo, featuring the word "Onan" in a stylized, bold, red font.



GeneratorJoe

4016 Quartz Drive
Santa Rosa, CA 95405
Phone: 707 539-9003
Fax: 707 539-5212

Email: sales@generatorjoe.NET
Web www.generatorjoe.NET

Cummins Power Generation is a subsidiary of Cummins Inc. Onan is a registered trademark of Cummins Inc.

WARNING: Backfeed to utility systems can cause electrocution or property damage. Do not connect to building electrical except through approved device and after building main breaker is opened.