



RV Marquis Gold™ 7000 GenSet



Generator Joe

4016 Quartz Drive
 Santa Rosa, CA 95405
 Phone: 707 539-9003
 Fax: 707 539-5212
 Email: sales@generatorjoe.NET
 Web www.generatorjoe.NET

RV GenSet

- **Quietest GenSet in Its Class**
- **Exceptionally Low Vibration Levels**
- **Integrated Design With Enclosed Muffler for Easy Installation**
- **Self-Diagnostic Capability to Simplify Troubleshooting**
- **Runs Two ACs With Power to Spare**
- **Digital Voltage Regulations for Stability as Appliance Loads Change**
- **3-Year Limited Warranty, Lifetime Drive Warranty**
- **Gasoline or LP Fueled**

Ratings and Models

Model	Fuel	Hz	RPM	Watts	Voltage	Amps	Ph	Circuit Breaker
7 HGJAB-900A	Gasoline	60	2880	7000	120	58.3	1	(2) 30A
7 HGJAB-1036	Gasoline	60	2880	7000	120	58.3	1	(1) 30A, (1) 20A HACR
6.5 HGJAB-902A	LP Liquid	60	2880	6500	120	54.2	1	(2) 30A
6.5 HGJAB-1037	LP Liquid	60	2880	6500	120	54.2	1	(1) 30A, (1) 20A HACR
6.5 HGJAB-904A	LP Vapor	60	2880	6500	120	54.2	1	(2) 30A

Ratings apply to altitudes up to 3000 ft (1524 m).

Derating: Power output will decrease 3.5% for each 1000 ft (305 m) above 3000 ft (1524 m), temperature derate not required for temperatures under 120° F (49.2° C).

Weight, Size and Sound Level

- 290 lb
- Length: 33.6 in (853 mm); Width: 22.2 in (563 mm); Height: 16.7 in (425 mm)
- 67 dB(A) at 10 ft (3 m), 4 kW load installed in a typical RV

Standard Features

- Mechanical governor adjustable from service side
- Onan Performer™ OHV engine
- Pressurized Thru Flow cooling system
- 4-point focalized mounting system with vibration isolators
- Universal mounting tray with structural capability to support the genset in RV applications
- Integral USDA Forest Service-approved spark-arrestor muffler
- Replaceable dry element air cleaner
- Integral control box
- Instant One-Touch stop switch
- Electronic ignition
- Automatic choke
- Fuel filter
- Electric fuel pump (gasoline), electric fuel solenoid (LPG)
- Positive fuel shutoff (3 psi)
- Enclosed muffler
- Sound-attenuated housing
- Remote waterproof connector
- Automotive type starter with automatic start disconnect
- Spin-on, full-flow oil filter
- Low oil pressure protection
- Overspeed/underspeed protection
- Overcurrent protectors (see Models and Ratings section)
- Low power factor field overcurrent protection
- 120-inch generator output leads
- Digital voltage regulation

Engine Detail

Model: Onan Performer™ OHV EH65V gasoline engine

Design: 4-cycle, OHV, 90-degree V-Twin

Compression Ratio: 8:1

Displacement: 39.8 in³ (653 cm³)

Maximum Power: Gasoline-fueled models: 14.0 bhp (10.5 kW), LP-fueled models: 11.6 bhp (8.6 kW)

Cooling: Centrifugal blower, generator mounted for high effectiveness, pressurized system, vertical flow

Cooling Air Volume: 500 ft³/min (14.2 m³/min) at 60 Hz, 417 ft³/min (11.8 m³/min) at 50 Hz. Air flow includes engine, generator control cooling air flow

Fuel System: Replaceable dry element air cleaner

- (Gasoline) Sidedraft carburetor
- Electronic fuel pump with positive fuel shutoff (3 psi), fuel lift 3 ft (0.9 m)
- Automatic choke with vacuum pull-off
- Combustion air volume at rated load: 18.8 ft³/min (0.53 m³/min)
- (LPG) Sidedraft mixer with demand regulator
- Combustion air volume at rated load: 17.5 ft³/min (0.49 m³/min)

Average Fuel Consumption:

Gasoline

	No Load gph/(l/h)	Half Load gph/(l/h)	Full Load gph/(l/h)
50 and 60 Hz	0.42 (1.6)	0.73 (2.8)	1.22 (4.6)

LPG

	No Load lb/h(kg/h)	Half Load lb/h(kg/h)	Full Load lb/h(kg/h)
50 and 60 Hz	2.2 (1.0)	3.5 (1.8)	5.3 (2.4)

Ignition System: Electronic magneto type with resistor plugs

Starting System: Remote, 12 V, 3-wire, negative ground automotive type starter with steel pinion and ring gear, automatic start disconnect, connector for remote start cable, start-stop rocker switch mounted on set control

Lubrication: Full pressure positive displacement lube oil pump, spin-on, full flow lube oil filter, low oil pressure shutdown, dipstick

Oil Capacity: 2.0 qt (1.9 L) including filter

Cylinder-Crankcase: Alloy aluminum with iron cylinder liners cast into the block, aluminum oil base

Cylinder Head: Aluminum, overhead valve

Generator Detail

Design: Onan, revolving field, AC, 2-pole self-excited, two bearing design

Insulation System and Temperature Rise: Meets ANSI/RVIA EGS-1, and CSA 946 requirements

Cooling: Direct drive centrifugal blower, cast aluminum housing for excellent heat transfer

Excitation: Digital voltage regulation

Rotor: Laminated electrical steel assembly press-fitted to shaft, balanced. Heavy insulated copper wire windings. Optimized air gap for improved waveform and motor starting.

Stator: Laminated electrical steel assembly, skewed for improved waveform. Heavy insulated copper wire windings.

DC Brushes: Electrographic; long life

Bearing: Double-sealed prelubricated ball bearings

GenSet Performance

Air Conditioner Starting: Two 13,500 Btu air conditioners with 3000 W baseload at 100°F (38°C) at 500 ft (152 m) elevation.

Frequency and Voltage Regulation: No load to full load, 0%

Sound Level: 67 dB(A) at 10 ft (3 m), 4 kW load installed in a typical RV.



GeneratorJoe

4016 Quartz Drive
Santa Rosa, CA 95405
Phone: 707 539-9003
Fax: 707 539-5212

Email: sales@generatorjoe.NET
Web www.generatorjoe.NET

Basic Dimensions

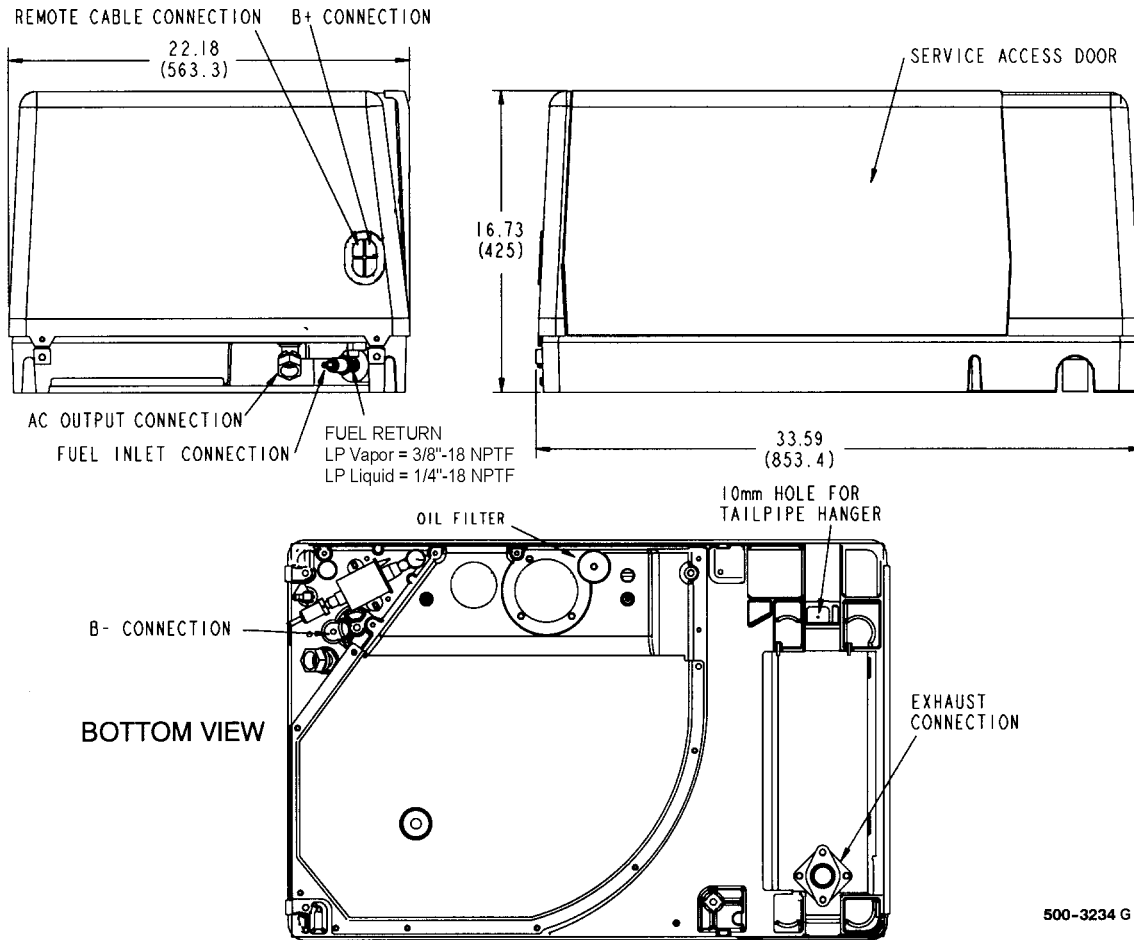

CAUTION: Drawings are supplied for reference only and should not be used for installation. See Installation Manual for details.

Options and Accessories

- Remote start/stop rocker switch (P/N 300-5331)
- Remote control with start/stop switch and running time meter (P/N 300-5332)
- Remote control w/start/stop switch and DC voltmeter (P/N 300-5333)
- Remote control plug and wire harness (10 ft - P/N 338-3489-01, 30 ft - P/N 338-3489-02)
- Battery, 12 V, 360 cold cranking amps at 0° F (-18° C)
- LPG vapor fuel conversion kit, (P/N 148-1161)
- Underfloor mounting kit (P/N 405-6699)
- Installation template (P/N 539-2057)
- Tailpipe kit (P/N 155-3421)
- Exhaust tube, straight with flanged end (3 in - P/N 155-2610, 7 in - P/N 155-2424, 12.5 in - P/N 155-2610-01)



GeneratorJoe

4016 Quartz Drive
 Santa Rosa, CA 95405
 Phone: 707 539-9003
 Fax: 707 539-5212
 Email: sales@generatorjoe.NET
 Web www.generatorjoe.NET

Onan Testing for RV Application

Tested at extremes of temperature -20° F (-29° C) to 120° F (49° C) for starting and operation.
Tested with RV loads, air conditioners, microwaves, converter, TVs, VCRs.
Tested installed. Onan owns RVs used for product development testing.
Tested in high humidity conditions.
Tested in salt spray conditions.
Tested in heavy airborne dust conditions.
Field Test program.
Ratings apply to altitudes up to 500 ft (150 m), 85° F (29° C) ambient with muffler, in RV enclosure.
60 Hz models meet U.S. EPA Phase I and 1995-2001 California emission regulations for small off-road garden equipment engines.



Warranty Policy

The ONAN Limited Warranty covers virtually everything except routine maintenance for the first two years you own your RV generator set, and covers parts and labor on major power train and generator set parts during the third year. In addition, it also includes a free 90-day adjustment policy, which provides that Onan will make minor adjustments to your new genset during the first three months you own it - free of charge! Please note: The Onan 3-year Limited Warranty applies to RV generators used in RV applications only, and does not apply to RV generators used in commercial mobile applications.

The warranty period for the drive train belt and pulleys on the HGJ series generators used in recreational vehicles shall be the life of the generator. For the original owner, this drive train warranty shall include parts and labor. For succeeding owners, this power train warranty shall cover belt and pulley parts only.

For complete Onan Limited Warranty details see your Onan Distributor or Certified Onan Service Dealer.

After Sale Support

GENUINE ONAN MAINTENANCE CARE PARTS AND PRODUCTS

For your ongoing satisfaction and the dependability of your Onan RV genset, Onan offers a complete line of replacement and tune-up parts, oil and maintenance chemicals specifically designed for RV gensets. Easy to find at certified Onan RV Service and Parts Dealers coast-to-coast, Onan Green Label™ RV parts are packaged for correct selection and convenient on-board storage.

EASY TO LOCATE CERTIFIED ONAN RV SERVICE AND PARTS DEALERS

Onan has trained, tested and certified over 1,000 Onan RV Service Dealers covering most major metropolitan areas in the U.S. and Canada.



See Your Onan Distributor:



Generator Joe

4016 Quartz Drive
Santa Rosa, CA 95405
Phone: 707 539-9003
Fax: 707 539-5212
Email: sales@generatorjoe.NET
Web www.generatorjoe.NET

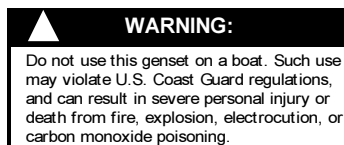

!

Onan is a registered trademark of Onan Corporation.
Printed in U.S.A.

WARNING: Backfeed to a utility system can cause electrocution and/or property damage. Do not connect to any building's electrical system except through an approved device or after building main switch is open.