

Features

Honda GX340 Engine

You expect the best; you get the best. The Honda GX340 engine has more power, lower fuel consumption, and lower emissions than previous versions.

Bi-Fuel

Designed to easily run and transition between two fuel sources; natural gas and gasoline.

Low Oil Protection

In the event there is low oil level, the engine will shut down, to protect the engine from damage.

Sturdy Wrap-Around Welded Tubular Cradle

We use 1"-14 gauge steel for dependable durability.

7 Gallon Fuel Tank

The EPA-approved steel fuel tank design eliminates hydrocarbon emissions.

Premium Square D Circuit Breakers

Square D is the industry leader in circuit breaker protection.

100% Load Tested

Every generator is fully tested prior to leaving our facility.

HOME POWER®

6,000 Surge Watts
5,500 Continuous Watts

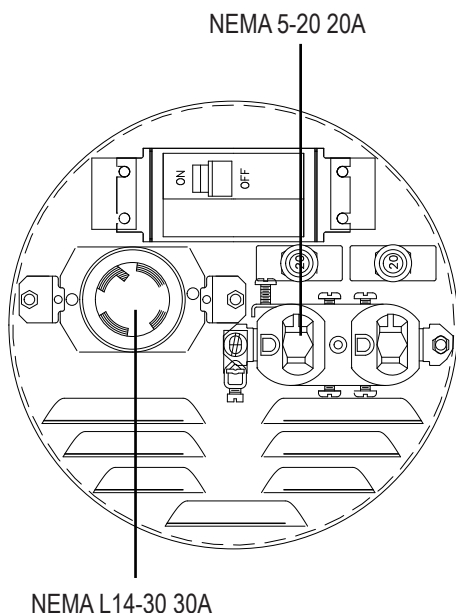

Optional Accessories

Two Wheel, Flat-Free Dolly Kit

Portability is important to get your generator where it needs to be.

Generator Cover

When your generator is not in use, a cover will keep it dust and debris free.

Plug-In Line Voltage Monitor

For when you want to verify the voltage output.

WINCO Emergency Transfer Service Kit

You will be able to set up your generator quickly and safely to restore power to critical circuit breakers.

30 Amp (NEMA L14-30P) Plug

You supply the length of cord you need. We offer the plug.

Low Pressure Fuel Solenoid

For peace of mind when you have to run your generator unattended.

Maintenance Kit

Keep the engine at its peak performance to ensure the generator will be ready when needed most.

Battery

Interstate group 20 300 CCA.

GENERATOR

SURGE WATTS ⁽¹⁾	6,000
CONTINUOUS WATTS ⁽¹⁾	5,500
CONTINUOUS AMPS ⁽¹⁾	45.8/22.9
OUTPUT	120/240 V
VOLTAGE REGULATION	CAPACITOR +/-5%
FREQUENCY REGULATION	+/-3%
MAIN CIRCUIT BREAKER	25 AMP
BONDED NEUTRAL	YES
120 VOLT RECEPTACLES	(1) NEMA 5-20 20A DUPLEX
120/240 VOLT RECEPTACLES	(1) NEMA L14-30 30A
LIFTING EYE	NO
2-WHEEL DOLLY KIT	OPTIONAL
PROTECTIVE ROLL FRAME	14 GAUGE STEEL
GENERATOR WARRANTY ⁽²⁾	2 YRS RESIDENTIAL

NOTES: (1) Based on gasoline fuel. Derate 20% for Natural Gas. (2) For complete generator warranty information, refer to the HPS6000HE manual

SHIPPING

DIMENSIONS (LxWxH)	32.75" x 22.5" x 22"
NET WEIGHT	202 LBS
SHIPPING DIMENSIONS	33" x 25" x 26"
SHIP WEIGHT	224 LBS
FREIGHT CLASS	70



ENGINE

ENGINE BRAND	HONDA
ENGINE MODEL	GX340
ENGINE STARTER	RECOIL/ELECTRIC
ENGINE SPEED	3600 RPM
ENGINE CYLINDERS	SINGLE
DISPLACEMENT/TYPE	389 CC / OHV
LOW OIL PROTECTION	STANDARD
RECOMMENDED OIL	10W-30
OIL CAPACITY	1.2 QTS
dba AT 7 METERS	72
MOTOR STARTING (CODE G) ⁽¹⁾	2 HP
BATTERY SIZE ⁽²⁾	BCI 20 OR 24HL 300 CCA
EPA APPROVED	YES
CARB APPROVED	NO
CSA APPROVED	NO
UL LISTED	NO
ENGINE WARRANTY ⁽³⁾	3 YRS RESIDENTIAL

NOTES: (1) Code G capacitor start motor. (2) Battery not included (3) Contact your local Honda service center for engine warranty assistance.

FUEL

FUEL TANK	7 GAL
FUEL GAUGE	ON TANK
FUEL USE: GASOLINE	1 GAL/HR
NATURAL GAS	160 FT ³ /HR - 163,200 BTU/HR



GeneratorJoe®

GeneratorJoe®

4723 Muirfield Court
 Santa Rosa, CA 95405
 Phone: 707 542-2224
 Fax: 707 542-2227

Email: sales@generatorjoe.Net
 Web: www.generatorjoe.NET